

# User Manual

## Ventilation Systems for residential use only



VB0092

**Solo 1.5**

---

**Solo 2.0**

---



VB0093

**Duo 1.2**

---

**Duo 1.4**

---

**Duo 1.9**

---

Address of your installer



03329 rev. B

# ABOUT THIS MANUAL/PRODUCT

The purpose of this manual is to help you with the use of your unit. Section 2 (How to Operate the Unit Using Controls) shows you how you can operate the unit in no time. Section 3 deals with maintenance and explains how to maintain the unit to ensure maximum operation and performance. In the other sections, for example Troubleshooting, you will learn how to solve minor problems (Section 4); plus other important information which we urge you to read.

In simplifying explanations, all drawings (figures) in this manual show the unit installed in the "normal" position. However, please note that your unit can be installed in either the "normal" or "reverse" (upside down) position. Several models are described in this publication. Some details of your unit may be slightly different than the ones shown, as the illustrations are typical ones.

We welcome any suggestions you may have concerning this manual and/or the unit, and we would appreciate hearing your comments on ways to better serve you. Please forward all correspondence to us at the address indicated on the product's registration card included with this manual.

This manual uses the following symbols to emphasize particular information:

## **WARNING**

**Identifies an instruction which, if not followed, might cause serious personal injuries including possibility of death.**

## **CAUTION**

**Denotes an instruction which, if not followed, may severely damage the unit and/or its components.**

**NOTE:** Indicates supplementary information needed to fully complete an instruction.

Finally, we want to congratulate you on your purchase of this excellent unit which will allow you and your family to enjoy fresh air throughout your home for years to come!

## **CAUTION**

**Some activities create dust or vapors which may damage your unit. You must therefore turn off and unplug your unit in the following situations:**

- major renovation work
- housing construction
- sanding (e.g. gypsum joints, etc.)
- varnishing

**During very heavy snowstorms, the unit should also be turned off to avoid problems caused by snow entering the unit, even if it is equipped with an anti-gust intake hood.**

---

# TABLE OF CONTENTS

---

<b>1.</b>	<b>YOUR UNIT AND ITS PURPOSE</b>	<b>4-6</b>
1.1	<i>Unit Description</i>	4
1.2	<i>Purpose of the Ventilation System</i>	4
1.3	<i>Recovery</i>	5
1.4	<i>Defrost Mode</i>	6
1.5	<i>Specifications</i>	6
<b>2.</b>	<b>HOW TO OPERATE THE UNIT USING CONTROLS</b>	<b>7-13</b>
2.1	<i>Instructions Regarding your Control Devices</i>	7-8
2.2	<i>Using the Altitude Main Control</i>	9-11
2.3	<i>Using the Venta Main Control</i>	12
2.4	<i>Using the Optional Controls</i>	13
<b>3.</b>	<b>MAINTENANCE</b>	<b>14-17</b>
3.1	<i>Every Three Months</i>	14-15
3.2	<i>Annual Maintenance (Fall)</i>	16-17
3.2.1	<i>Clean the Recovery Module</i>	16
3.2.2	<i>Clean the centrifugal fan wheels</i>	17
3.2.3	<i>Put the components back in place</i>	17
3.2.4	<i>Reconnect the power supply</i>	17
<b>4.</b>	<b>TROUBLESHOOTING</b>	<b>18</b>

# 1. YOUR UNIT AND ITS PURPOSE

## 1.1 UNIT DESCRIPTION

1. Basic filters
2. Blower
3. Condensation tray (on Solo unit only)
4. Heat recovery core or thermal wheel
5. Optional filter

*\*Units shown in normal position. Can also be installed upside down.*

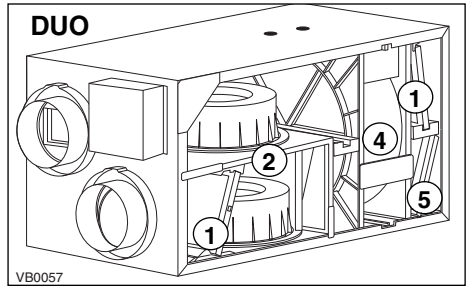
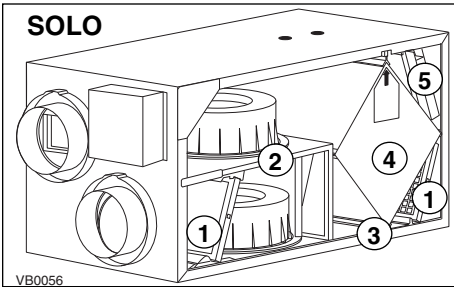

## 1.2 PURPOSE OF THE VENTILATION SYSTEM

Your ventilation system is designed to provide fresh air, warmed outdoor air to your home while exhausting stale, humid air from your home. By eliminating accumulated pollutants and humidity, it maintains an optimum air quality and an ideal relative humidity.

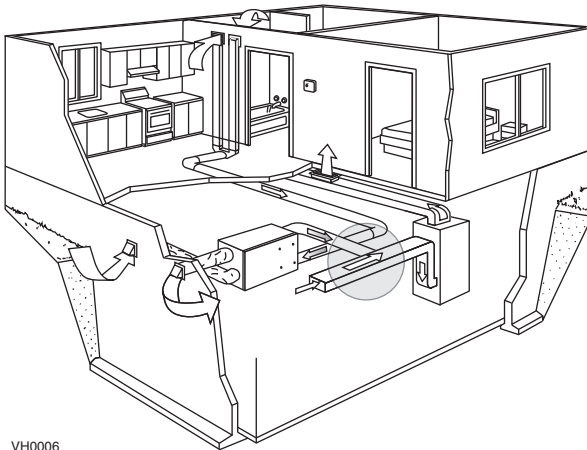

- NOTES: 1. Shown with a forced air system. Can also operate on its own.  
2. Installation may vary according to the model number and the position (normal or reverse) in which the unit is installed.

## 1.3 RECOVERY

- A) Units with a heat recovery core (**Solo units**) are designed specifically to control excess humidity and reduce ventilation costs by recovering the heat energy from the exhausted air, and using that same heat energy to warm the fresh air being supplied. This heat recovery process is accomplished in such a way that the stale air is never mixed with the fresh air.

### Example (in winter):

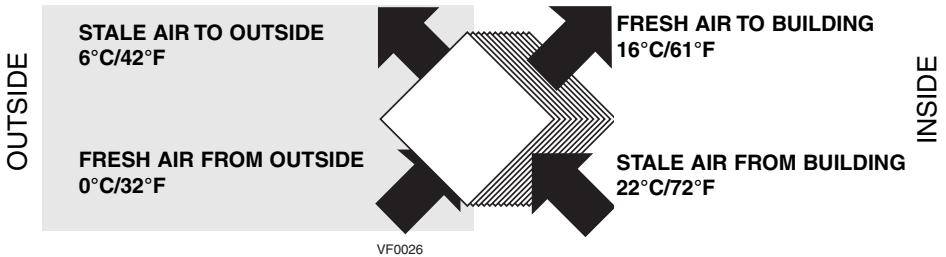

- B) Units equipped with a thermal wheel (**Duo units**) can reduce ventilation costs in winter as well as in summer by maintaining indoor humidity level for maximum comfort.

1. During the heating season, the unit draws the humidity and heat from the stale air and transfers them, in part, to the cold air entering the house, thus avoiding dryness problems and providing maximum comfort (**Example 1**).
2. During the cooling season, the unit reverses the process, preventing the humidity from the outside air from entering into the house (**Example 2**).

### Example 1 (in winter):

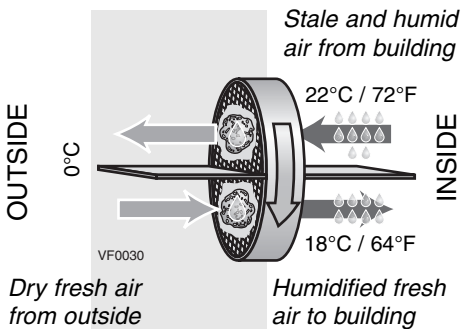

Heating season

### Example 2 (in summer with air conditioning):

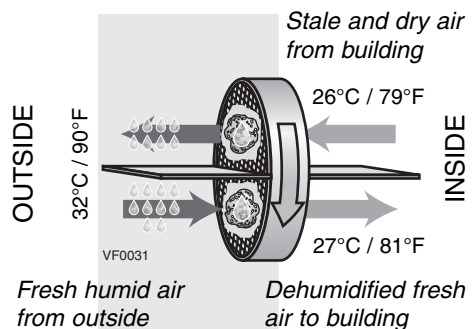

Cooling season

## 1.4 DEFROST MODE

---

When the outside temperature is below -5°C (23°F), recovery (of heat or energy) creates frost in the module. To maintain its proper operation, the unit is programmed to defrost the recovery module. The defrost frequency varies according to the outside temperature. Defrost lasts 6 minutes for Solo models and 9 minutes for Duo models (or 10 minutes for all models if set on “Extended Defrost”). During the defrost cycle, the unit shifts to maximum speed and the dampers close.

After defrosting, the unit returns to the operating mode selected by the user.

## 1.5 SPECIFICATIONS

---

<b>Model</b>	<b>Solo 1.5</b>	<b>Solo 2.0</b>
Width	30¼” (768 mm)	30¼” (768 mm)
Height	16½” (419 mm)	16½” (419 mm)
Depth	17¼” (438 mm)	17¼” (438 mm)
Weight	65 lb (29.5 kg)	67 lb (30.4 kg)
Electrical supply	120 V, 60 Hz	120 V, 60 Hz
Power Consumption	150 Watts	240 Watts

<b>Model</b>	<b>Duo 1.2</b>	<b>Duo 1.4</b>	<b>Duo 1.9</b>
Width	30¼” (768 mm)	30¼” (768 mm)	30¼” (768 mm)
Height	16½” (419 mm)	16½” (419 mm)	16½” (419 mm)
Depth	17¼” (438 mm)	17¼” (438 mm)	17¼” (438 mm)
Weight	71 lb (32.2 kg)	71 lb (32.2 kg)	73 lb (30.4 kg)
Electrical supply	120 V, 60 Hz	120 V, 60 Hz	120 V, 60 Hz
Power Consumption	160 Watts	160 Watts	250 Watts

## 2. HOW TO OPERATE THE UNIT USING CONTROLS

### 2.1 INSTRUCTIONS REGARDING YOUR CONTROL DEVICES

Determine which controls are installed in your house and identify them in the following pages (this page and the following page). Then, you can proceed to the pages indicated to learn how to CONTROL your unit.

#### MAIN CONTROLS

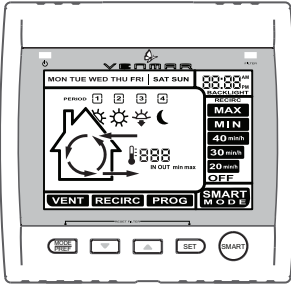

VC0101

Altitude Main Control .....Page 9-11

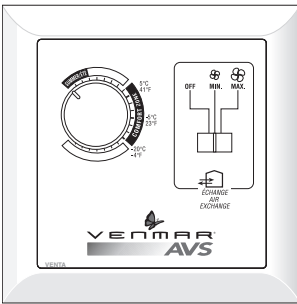

VC0010

Venta Main Control .....Page 12

## 2.1 INSTRUCTIONS REGARDING YOUR CONTROL DEVICES (CONT'D)

### OPTIONAL CONTROLS

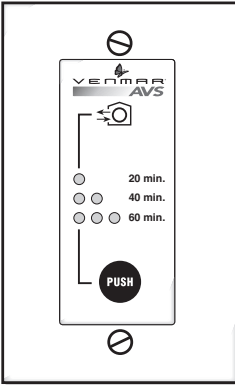

VC0007

20/40/60 minute push-button timer .....Page 13

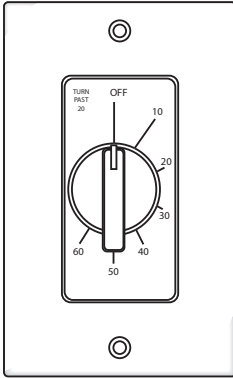

VC0017

60-minute crank timer .....Page 13



VC0083

Dehumidistat .....Page 13

## 2.2 USING THE ALTITUDE MAIN CONTROL

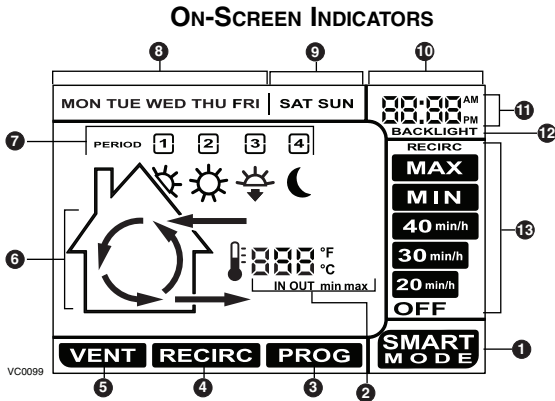

- ❶ **SMART Mode.** Entirely automatic mode optimizing the ventilation.
- ❷ **Temperature Indicators.**
- ❸ **Program Mode.** Allows to program the desired ventilation according to the period of the day.
- ❹ **Recirculation Mode.** Manual mode performing air recirculation inside the house.
- ❺ **Ventilation Mode.** Manual mode performing air exchange with the outside.
- ❻ Animated Arrows showing ventilation status (recirculation or air exchange).
- ❼ Periods of the day (morning, day, evening and night).
- ❽ Week days.
- ❾ Week-end days.
- ❿ Hour display.
- ⓫ AM or PM display.
- ⓫ Appears only when setting backlight preferences.
- ⓫ Ventilation / Recirculation speeds and programming options.

### CASING INDICATORS AND KEYS

- A SMART key:** Enables and disables the **SMART** mode.
- B Set key:**
  - Press 3 seconds to access setting periods for Program mode.
  - Confirms the chosen option and goes to following setting.
- C Arrow keys:**
  - Adjust ventilation and recirculation speeds.
  - Allows to review the program's period.
  - Adjust Preference and Program values.
- D Mode / Pref key:**
  - Mode: Selects whether **Ventilation, Recirculation or Program** mode.
  - Pref: Push 3 seconds to access Preference settings.
- E Reset filter keys:** Press on **B** and **D** keys simultaneously for 5 seconds to turn off (reset) the filter maintenance indicator.
- F Power indicator:** Illuminates when the control is operating.
- G Filter maintenance indicator:** Perform filters maintenance.  
(Refer to Section 3 Maintenance).

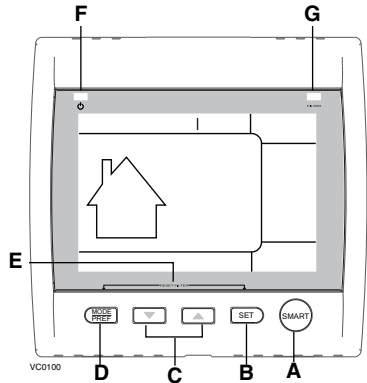

## 2.2 USING THE ALTITUDE MAIN CONTROL (CONT'D)

The Altitude main control is pre-programmed and ready to go. All you have to do is to set day and time. Then check the settings below and change if needed.

### SETTING PREFERENCES

Press on **MODE / PREF** key (D) for 3 seconds.

NOTE: You can exit Preferences setting by pressing on **MODE / PREF** key (D) for 3 seconds any time in the process, or wait 60 seconds. The modified values will be kept in memory.

### WHAT WILL YOU SEE

If the control will be set for the very first time, the current day will be the first setting to be made; **MON** (for Monday) will flash on screen.

If the control was previously set up, when setting preferences, the control returns to the last preference chosen on previous setting. While setting Preferences, the corresponding setting value flashes (e.g.: while setting current hour, hour is flashing).

### HOW TO PROCEED

For every settings in table below:

- Use   to select value.
- Press **SET** key (B) to confirm the selected preference and go to next setting.

SETTING	AVAILABLE VALUE	DEFAULT OPTIONS
CURRENT DAY	MON/TUE/WED/THU/FRI/SAT/SUN	MON
HOURLY DISPLAY	12:00 <sup>AM</sup> OR 24:00 <sub>PM</sub>	12:00 <sup>AM</sup> <sub>PM</sub>
CURRENT HOUR	DE 0 À 12 OR 24	12
CURRENT MINUTE	DE 00 À 59	00
TEMPERATURE UNIT	°C OR °F	°C
INSIDE TEMPERATURE DISPLAY	ON OR OFF	ON
MINIMUM OUTSIDE TEMPERATURE FOR AIR EXCHANGE*	-40°C TO 0°C OR -40°F TO 32°F	-25°C OR -13°F
MAXIMUM OUTSIDE TEMPERATURE FOR AIR EXCHANGE*	1°C TO 40°C OR 33°F TO 104°F	27°C OR 81°F
*IN PROG OR SMART MODE, THESE LIMIT VALUES ALLOW TO STOP AIR EXCHANGE WITH THE OUTSIDE		
BACKLIGHT COLOR	BLUE OR GREEN	BLUE
BACKLIGHT DISPLAY	AUTO OR ON	AUTO
AUTO: BACKLIGHT ACTIVATED 10 SECONDS WHEN ANY KEY IS PRESSED. ON: BACKLIGHT ALWAYS ON.		
OFF MODE FOR INTERMITTENT MODE	VENTILATION/RECIRCULATION OR VENTILATION/OFF	VENT/RECIRC.
AFTER A VENTILATION PERIOD, DETERMINES THE SECOND PART OF THE CYCLE (RECIRCULATION OR OFF).		

## 2.2 USING THE ALTITUDE MAIN CONTROL (CONT'D)

Pressing on **MODE / PREF** key (**D**) successively allows to go from **Ventilation** mode to **Recirculation** mode and then to **Program** mode (**VENT** 5 , **RECIRC** 4 and **PROG** 3 on control screen).

- In **Ventilation** Mode, use   to change the ventilation speed (displayed in ⑩ in all options except **RECIRC**).
- In **Recirculation** mode, use   to change the recirculation speed (displayed in ⑩, OFF, MIN, MAX).
- In **Program** mode, use   to review the period settings without changing them (the period icons are displayed in ⑦).

Pressing once on **A** allows to turn the ventilation unit in Smart mode. On this mode, the ventilation unit operation will be driven by the outdoor temperature and by the indoor conditions. Press once more to exit Smart mode.

### SETTING PERIODS FOR PROGRAM MODE

The Program Mode allows the user to customize the operation of his/her ventilation unit, for week and weekend days. All days are divided in 4 periods. The periods starting hour and ventilation speed are factory set (see below).

DAILY PERIODS DEFAULT SETTINGS		
PERIOD	STARTING HOUR	MODE
PERIOD 1 (MORNING)	6:00 AM	MIN
PERIOD 2 (DAY)	9:00 AM	20 MIN/H
PERIOD 3 (EVENING)	5:00 PM	MIN
PERIOD 4 (NIGHT)	11:00 PM	20 MIN/H

#### To change these values:

Press on **SET** key (**B**) for 3 seconds, **PROG** (for program) will appear on screen, and week days will flash.

NOTE: You can exit Periods setting by pressing on **SET** key (**B**) for 3 seconds any time in the process, or wait 60 seconds.

- Use   to select between setting week days or weekend days.
- Press **SET** key (**B**) to confirm the choice, and go to setting daily Period 1. (**Period 1** will appear on screen, and hour display will flash.)

- Use   to select the period starting hour.

NOTE: Time changes by 15 minutes increments.

- Press **SET** key (**B**) to confirm and go to select the ventilation speed or type (will flash on screen).
- Use   to select the ventilation speed or type.
- Press **SET** key (**B**) to confirm and go to daily Period 2. (**Period 2** will appear on screen, and hour display will flash.)

Proceed as for Period 1 for all daily periods. Once the ventilation speed or type for daily Period 4 has been selected:

- Press **SET** key (**B**) to confirm.

NOTE : If the week days were the first to be set, the weekend days will appear on screen; but if the weekend days were the first to be set, then the week days will appear on screen. (**Period 1** will appear on screen, and hour display will flash.)

- Set periods as described above.

## 2.3 USING THE VENTA MAIN CONTROL

**Location:** Located in the busiest area of the house.

**Purpose:** To adjust air supply and select desired indoor humidity level.

### ADJUSTING THE AIR SUPPLY CONTROL

- a) **Select** speed MIN. or MAX. using switch **A** (as shown on diagram).
- When MIN. (minimum speed) is selected, if the knob **B** is set above the click, the unit will exchange in low speed with the outside. If it is set below the click, the unit will exchange on high speed with the outside until the desired humidity level has been reached.
  - When MAX. (maximum speed) is selected, the unit will exchange on high speed with the outside either if the knob **B** is set below or above the click.
- b) To **turn the unit off**, place selector **A** at the “OFF” position. Optional controls, however, may still be active.

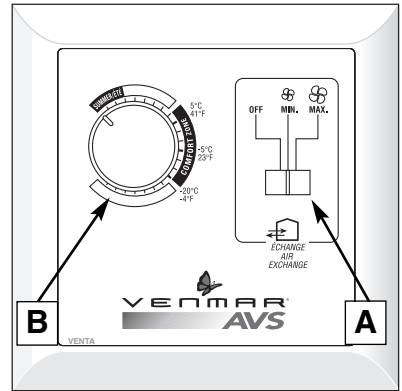

### ADJUSTING THE HUMIDITY CONTROL

#### Setting during the summer months:

During this period, unless being afflicted by breathing problems, using the humidity control is unnecessary. Set switch **A** to OFF. (Do not exchange in day time; exchange at night time, if cool outside or if it is not raining.)

#### Setting during the fall, winter and spring months:

- 1) Determine the humidity level in your house (bring the knob **B** counterclockwise to 20%, then bring it back clockwise slowly until you hear a “click”).
- 2) Set knob **B** to 1% under this temperature level or below the “click”.

NOTES: 1. Do not select a humidity level below 30%. This could lead to excessive dryness in the air causing discomfort to the occupants.  
2. When the humidity level is high, the unit automatically operates at maximum speed. If you change the setting of your “AIR SUPPLY” knob (**B**) at that time, it will remain at maximum speed until the humidity level is reduced, and then switch to the desired setting.

**It is possible (and normal) to experience condensation on your windows when drastic changes in temperature happen (for example: -5°C (23°F) to -20°C (-4°F) within few hours). In that case, we suggest waiting a few days to allow the situation to stabilize.**

## 2.4 USING THE OPTIONAL CONTROLS

### A) TIMERS

**Location:** Located in the bathroom or in other locations where there is temporary excess humidity or pollutants.

**Purpose:** To eliminate excess humidity produced by showers or other periodic activities producing pollutants.

#### **20/40/60-MINUTE PUSH-BUTTON TIMER:**

High speed activation times are in multiples of 20 minutes.

- Within 2 seconds, push one time for 20 minutes, two times for 40 minutes, or three times for 60 minutes activation. **Indicator then lights up and the system exchanges air at high speed.**
- Every 5 seconds, the indicator light flashes one time to indicate a 20-minute selection, two times for a 40-minute and three times for a 60-minute selection.
- To stop activation, push one more time. Unit then returns to its previous setting.

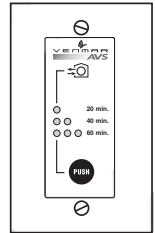

#### **60-MINUTE CRANK TIMER:**

This control makes the system operate at high speed for periods varying from 10 to 60 minutes.

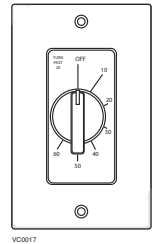

### B) DEHUMIDISTAT

**Location:** Located in the bathroom or in other locations where there is temporary excess humidity.

**Purpose:** To eliminate excess humidity produced by showers or other periodic activities producing humidity.

**In the fall, winter and spring:**

Adjust the knob to the desired maximum humidity level.

**NOTE:** Do not select a humidity level below 30%. This could lead to excessive dryness in the air causing discomfort for the occupants.

**In the summer:**

Adjust the knob to the "SUMMER" position.



### 3. MAINTENANCE

#### WARNING

Dangerous voltage may be present. During maintenance and repairs, the unit must always be turned off, then unplugged.

We take great care to minimize sharp edges; however, please proceed with caution when handling all components.

NOTE: Unit is shown in normal position but can be installed in either the “normal” or “reverse” (upside down) position.

#### MAINTENANCE PROCEDURE:

### 3.1 EVERY THREE MONTHS

Regular maintenance should be performed every 3 months. Annual maintenance should also take place every fall season.

1. Disconnect the power supply.
2. Unlatch the door. Lift the panel towards you. Hold it firmly and hit on the right side of the panel. The door should slide to the left.
3. Clean the inside of the door with a damp cloth.

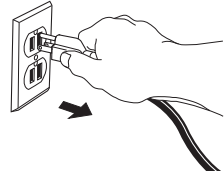

4. A) Clean the ***basic filters***
  - Remove filters.
  - Vacuum to remove most of the dust.
  - Wash with a mixture of warm water and mild soap. You may add bleach if you wish to disinfect (one tablespoon per gallon). Rinse thoroughly. Shake filters to remove excess water and let dry.

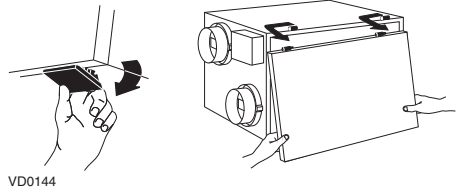

NOTE: Washing the filters in the top tray of the dishwasher is possible, but the aluminum frame might tarnish.

- B) Replace the ***optional filters*** if necessary.
  - Do not wash in water.

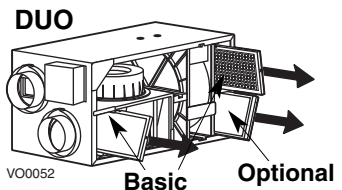
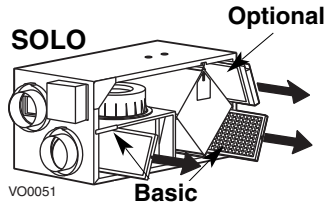

### 3.1 EVERY THREE MONTHS (CONT'D)

5. Clean the ***condensation tray*** with a damp cloth.
6. Check the exterior ***air intake hood***:
  - Make sure there are no leaves, twigs, ice or snow that could be drawn into the vent.
  - Clean if necessary.

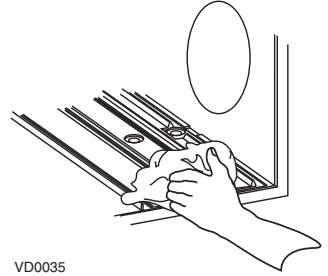

VD0035

#### **CAUTION**

**Even a partial blocking of this air vent could cause the unit to malfunction.**

7. Reassemble the components:
  - Filters
  - Door (The door is secured when you hear a click.)
8. Reconnect the power supply.

## 3.2 ANNUAL MAINTENANCE (FALL)

### WARNING

Dangerous voltage may be present. During maintenance and repairs, the unit must always be turned off, then unplugged.

We take great care to minimize sharp edges; however, please proceed with caution when handling all components.

Repeat steps 1 to 6 from the previous Section and continue with the following steps:

### CAUTION

Handle the recovery module with care.

#### 3.2.1 Clean the recovery module.

##### A- *Polypropylene core (Solo)*

- Remove the recovery core.
- Let it soak in a mixture of cold or lukewarm water and mild soap (dishwashing liquid).
- Rinse thoroughly.
- Shake the core to remove excess water and let it dry.

#### SOLO

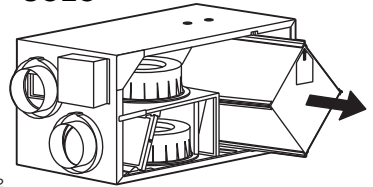

VD0142

### CAUTION

This type of recovery module cannot be washed with water.

##### B- *Thermal wheel (Duo)*

- Disconnect the thermal wheel wires.
- Remove the thermal wheel.
- Remove dust using a vacuum cleaner with a soft brush attachment.

#### DUO

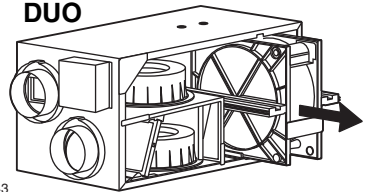

VD0143

## 3.2 ANNUAL MAINTENANCE (FALL) (COND'T)

### 3.2.2 Clean the centrifugal fan wheels

**A** Disconnect the fan motor wires.

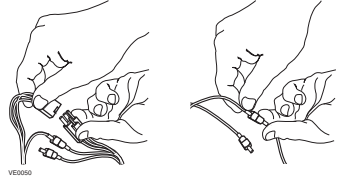

**B** Disconnect the rod activating the square damper.

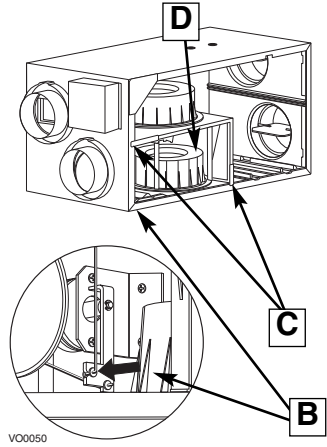

**C** Remove the two screws securing the fan assembly.

**D** Pull the fan assembly out of the unit

**E** Check for any dust accumulation on the blades.

#### CAUTION

**Do not oil the motor! It is already permanently lubricated.**

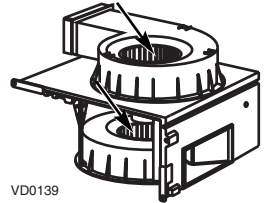

**F** Clean with a small brush if necessary.

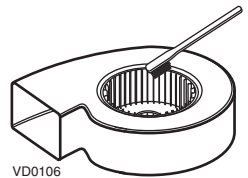



### 3.2.3 Put the components back in place (cf: Section 1.1):

- Fan assembly (screws, damper rod, fan motor wires)
- Recovery module
- Filters
- Door

### 3.2.4 Reconnect the power supply.

## 4. TROUBLESHOOTING

If you think your unit is malfunctioning, check some of the following.

	TYPE OF PROBLEM	TRY THIS...
1.	On Altitude wall control, there is no outside temperature displayed on screen   .	<ul style="list-style-type: none"><li>• At its very start-up or after a power failure, it takes some minutes before the outside temperature appears on screen. Set the wall control on MIN or MAX in VENT Mode.</li><li>• If the problem is not solved by the above, contact your installer.</li></ul>
2.	On Altitude wall control, error code E1, E3 or E4 appears on screen.	<ul style="list-style-type: none"><li>• Contact your installer.</li></ul>
3.	Nothing works.	<ul style="list-style-type: none"><li>• See if the unit is plugged in.</li><li>• See if the unit is receiving power from the house circuit breaker or fuse.</li></ul>
4.	Noisy unit.	<ul style="list-style-type: none"><li>• Clean the fan assembly (see Section 3.2). If the problems is not solved, contact your installer.</li></ul>
5.	Condensation on windows. (Air too humid.)	<ul style="list-style-type: none"><li>• Adjust the humidity control knob as per instructions (see Section 2).</li><li>• Operate the unit at maximum speed (MAX.) during activities generating excess humidity (family gatherings, extra cooking, etc.).</li><li>• Leave curtains half-open to allow air circulation.</li><li>• Store all firewood in a close room with a dehumidifier or in a well ventilated room, or store the wood outside.</li><li>• Keep the temperature in your house above 18°C (64°F).</li></ul>
6.	Air too dry.	<ul style="list-style-type: none"><li>• Do not adjust your humidity control below -20° C (30%).</li><li>• Operate the unit at low speed (MIN.).</li><li>• Temporarily switch to the intermittent mode.</li><li>• Temporarily use a humidifier.</li></ul>
7.	Air too cold at the air supply grille.	<ul style="list-style-type: none"><li>• Make sure the outside hoods are not blocked.</li><li>• Operate the unit at low speed (MIN.).</li><li>• Have the system's balancing checked.</li><li>• Have the unit's defrost system checked.</li><li>• Install a duct heater.</li></ul>

If the problem persists, contact your installer at the telephone number and address indicated on the first page of this manual or call the following phone number for assistance:

1-800-567-3855 (Canada and United States)