

Installer Manual

Ventilation systems for residential use only



VB0092

Solo 1.5 (part nos 43720 and 43725)

Solo 2.0 (part nos 45720 and 45725)



VB0093

Duo 1.2 (part no. 43710)

Duo 1.4 (part no. 43700)

Duo 1.9 (part no. 45700)



7 72371 04568 2



Table of Contents

1.	SERVICE	4
	1.1 3-D Drawing	4
	1.2 Parts Ordering Chart	5
	1.3 Technical Support.....	5
2.	SIZING	6
3.	UNIT TYPE & DEFROST SETTING VS GEOGRAPHICAL LOCATION	7
4.	TECHNICAL DATA	8
	4.1 Air Distribution (Normal Operation)	8
	4.2 Air Distribution (Defrost and/or Filtration Mode).....	8
	4.3 Defrost Cycles Tables	8
	4.4 Dimensions.....	9
	4.5 Controls and Link Options	9
	4.6 Specifications	9
5.	TYPICAL INSTALLATIONS	10
	5.1 Fully Ducted System	10
	5.2 Exhaust Ducted System (<i>Source Point Ventilation</i>)	10
	5.3 Simplified (<i>Volume Ventilation</i>)	10
6.	INSTALLATION	11-16
	6.1 Locating and Mounting the Unit	11
	6.2 Planning of the Ductwork	11
	6.3 Calculating the Duct Size	12
	6.3.1 Example Calculation.....	12
	6.3.2 Example of a Design for a Fully Ducted System	12
	6.4 Installing the Ductwork and Registers.....	13-14
	6.4.1 Fully Ducted System	13
	6.4.2 Exhaust Ducted System (<i>Source Point Ventilation</i>)	13
	6.4.3 Simplified Installation (<i>Volume Ventilation</i>).....	14
	6.5 Connecting the Duct to the Unit	15
	6.6 Installing the Exterior Hoods	16
	6.7 Connecting the Drain (Solo only)	16
7.	CONTROL DEVICES	17-18
	7.1 Main Controls	17
	7.2 Optional Controls	17
	7.3 Other Features	18

Table of Contents (cont'd)

8.	INSTALLATION OF THE CONTROLS	18-22
8.1	Dimensions and Specifications	18
8.2	Installation of the Main Control	19-21
8.2.1	Altitude Main Control Installation	19
8.2.2	Venta Main Control Installation	20
8.2.3	Main Control Electrical Connection.....	21
8.3	Optional Controls Electrical Connection	21
8.4	Electrical Connection to the Furnace.....	22
8.5	Furnace Interlock Types.....	22
9.	WIRING DIAGRAMS	23-24
10.	AIR FLOW BALANCING.....	25
11.	OVERALL VERIFICATION	26
11.1	Main Controls.....	26
11.2	Optional Controls	26
12.	MAINTENANCE / INSTRUCTIONS FOR USER	27
13.	TROUBLESHOOTING.....	27-28
14.	REFERENCES	28

About this Manual

This manual uses the following symbols to emphasize particular information:

WARNING

Identifies an instruction which, if not followed, might cause serious personal injuries including possibility of death.

CAUTION

Denotes an instruction which, if not followed, may severely damage the unit and/or its components.

NOTE: Indicates supplementary information needed to fully complete an instruction.

1. Service

1.1 3-D DRAWING

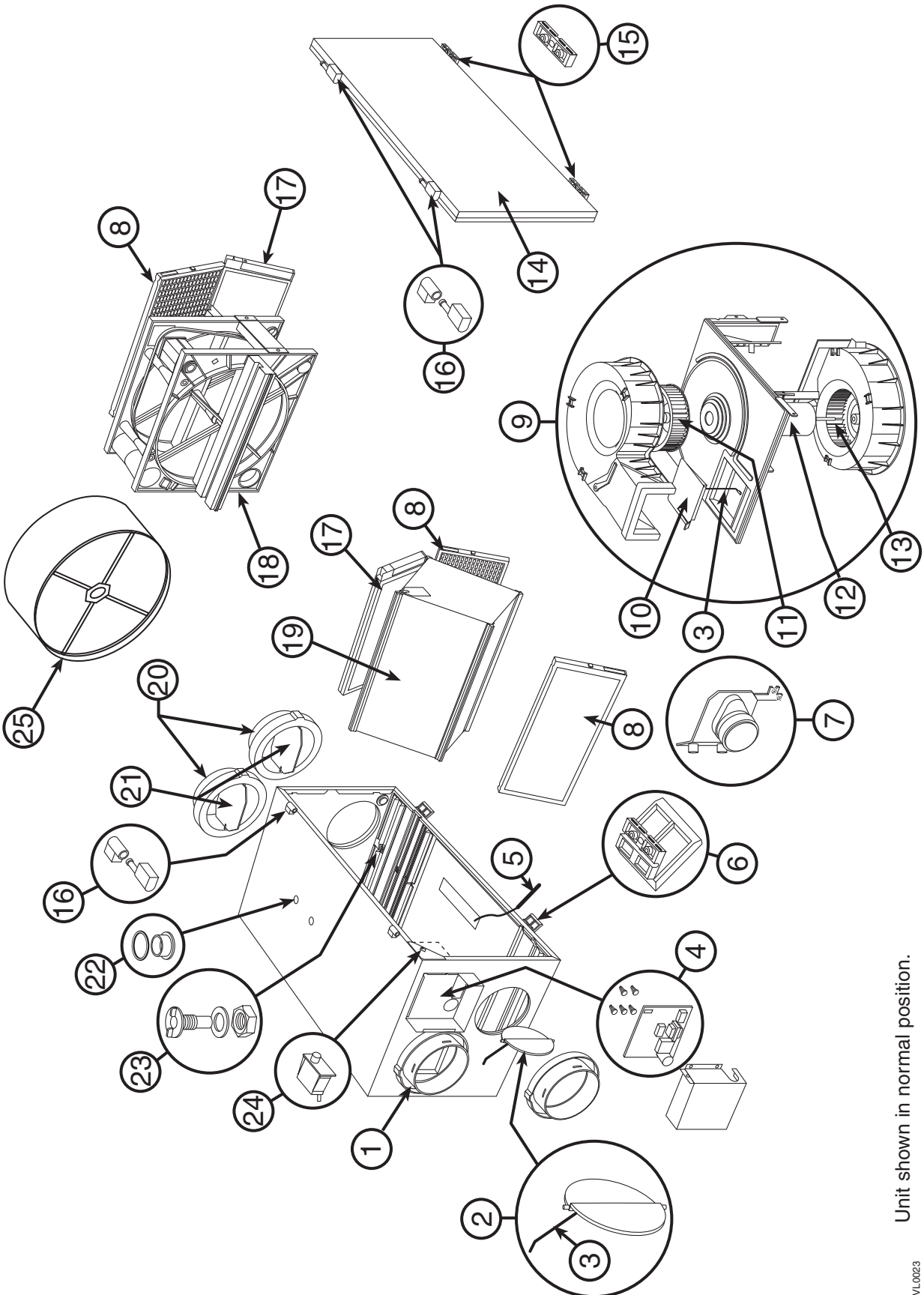

Unit shown in normal position.

1. Service (cont'd)

1.2 PARTS ORDERING CHART

No	Description	SOLO 1.5	SOLO 2.0	DUO 1.2	DUO 1.4	DUO 1.9
		(A) 43720 (B) 43725	(A) 45720 (B) 45725	43710	43700	45700
1	Double Collar Port no. 2	02257	02257	02257	02257	02257
2	Damper no. 1 (kit)	12454	12454	12454	12454	12454
3	Damper Rod (kit)	13037	13037	13037	13037	13037
4	Electronic Board & spacers (kit)	13038	13038	13039	13039	13039
5	Thermistor (kit)	12895	12895	12895	12895	12895
6	Door Latches & screws	00886 (2)	00886 (2)	00886 (2)	00886 (2)	00886 (2)
		00601 (4)	00601 (4)	00601 (4)	00601 (4)	00601 (4)
7	Damper Actuator Assembly	13734	13734	13734	13734	13734
8	Basic Filter	03308	03308	03308	03308	03308
9	Blower Assembly	12908	12912	12909	12909	12911
10	Square Damper (kit)	13033	13033	13033	13033	13033
11	Top Wheel	02238	02238	02238	02239	02239
12	Motor	12109	12157	12109	12109	12157
13	Bottom Wheel	02240	02240	02239	02239	02240
14	Door Ass'y (including 15 & 16)	13346	13346	13346	13346	13346
15	Door Latches (keeper) & Screws	00887 (2)	00887 (2)	00887 (2)	00887 (2)	00887 (2)
		00601 (4)	00601 (4)	00601 (4)	00601 (4)	00601 (4)
16	Hinge Ass'y (kit)	13036	13036	13036	13036	13036
17	Pleated Optional Filter	03316	03316	03316	03316	03316
	Charcoal Optional Filter	03315	03315	03315	03315	03315
	Electronic Optional Filter	03314	03314	03314	03314	03314
18	12" Cassette (incl. motor)	N/A	N/A	-	15184	-
	14" Cassette (incl. motor)	N/A	N/A	15185	-	15185
19	Recovery Core	(A) 03322	(A) 03322	N/A	N/A	N/A
		(B) 03311	(B) 03311			
20	Balancing Double Collar Port	02256	02256	02256	02256	02256
21	Balancing Damper	02253	02253	02253	02253	02253
22	Snap Bushing DP-750 & O-Ring	03324 (2)	03324 (2)	03324 (2)	03324 (2)	03324 (2)
		03310 (4)	03310 (4)	03310 (4)	03310 (4)	03310 (4)
23	Drain Connector (kit)	03203	03203	N/A	N/A	N/A
24	Door Switch (SPST), E69 10A	01825	01825	01825	01825	01825
25	Media (14" Wheel)	N/A	N/A	15186	-	15186
	Media (12" Wheel)	N/A	N/A	-	15187	-

Please take note that parts not listed are not available; those parts require assembly knowledge that only manufacturer can guarantee.

TO ORDER PARTS: Contact your local distributor.

1.3 TECHNICAL SUPPORT (FOR ASSISTANCE)

For assistance, call on weekdays, 8:30 AM to 5:00 PM (Eastern Standard Time).

NOTE: Do not call this number for ordering parts.

Canada & U.S.A.: 1-800-649-0372 (toll free)

2. Sizing

These are the two most common methods used to evaluate the ventilation needs of a house:

CSA F326 and Canadian Building Code:

- High speed: 10 cfm per room
20 cfm for the master bedroom and the basement
- Low speed: 40-60% of high speed

ASHRAE Standard 62-2001:

- 0.35 air change per hour

Refer to ventilation code of your area to determine which method to use.

Example:

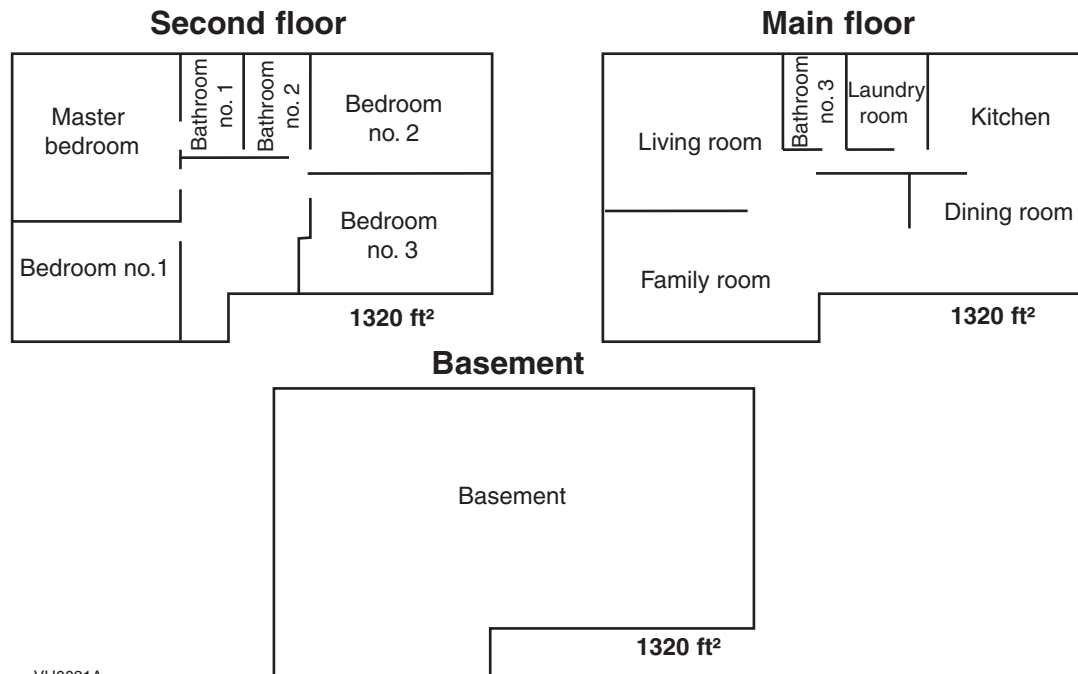

VH0021A

CSA F326

Kitchen	(10 cfm)
Dining room	(10 cfm)
Living room	(10 cfm)
Family room	(10 cfm)
Master bedroom	(20 cfm)
Bedroom no. 1	(10 cfm)
Bedroom no. 2	(10 cfm)
Bedroom no. 3	(10 cfm)
Bathroom no. 1	(10 cfm)
Bathroom no. 2	(10 cfm)
Bathroom no. 3	(10 cfm)
Laundry room	(10 cfm)
Basement	(20 cfm)

Total

150 cfm

ASHRAE Standard 62-1989

Volume of basement	10560 ft ³
Volume of main floor	10560 ft ³
Volume of second floor	10560 ft ³
Total volume	31680 ft³
	x 0.35/h
	11090 ft ³ /h
	÷ 60 (min/h)

Total

185 cfm

4. Technical Data

4.1 AIR DISTRIBUTION (NORMAL OPERATION)

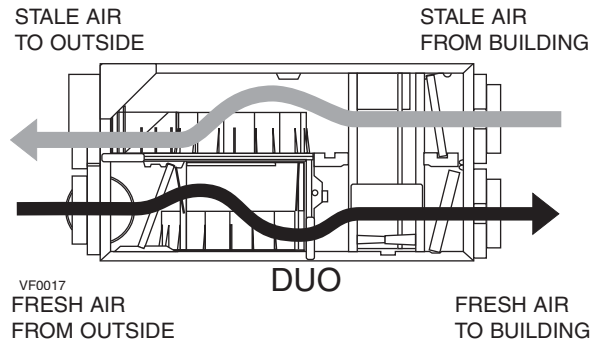
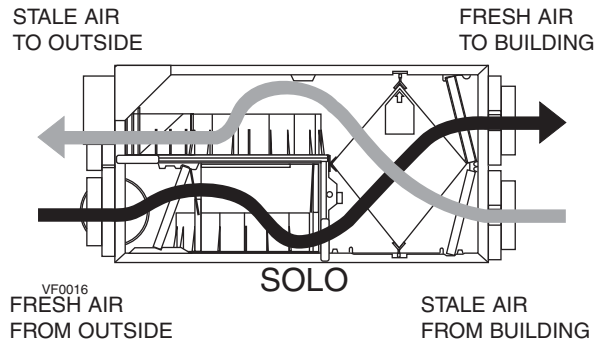

4.2 AIR DISTRIBUTION (DEFROST AND/OR FILTRATION MODE)

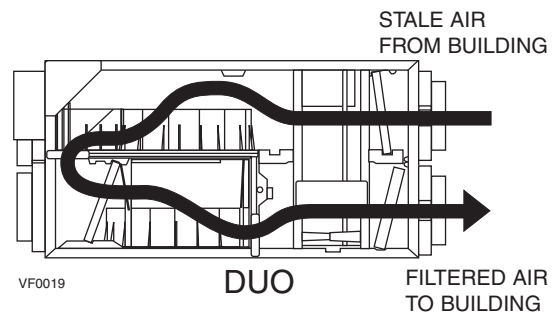
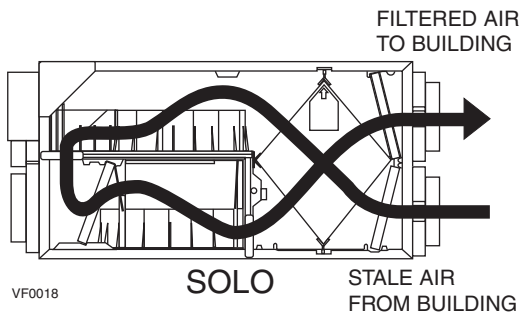

4.3 DEFROST CYCLES TABLES

SOLO units

Outside Temperature		Defrost Cycles		Extended Defrost Cycles	
Celcius (°C)	Fahrenheit (°F)	Defrosting (min.)	Operation time (min.) between each defrost cycle	Defrosting (min.)	Operation time (min.) between each defrost cycle
-5	23	6	60	10	30
-15	5	6	32	10	20
-27	-17	6	20	10	15

DUO units

Outside Temperature		Defrost Cycles		Extended Defrost Cycles	
Celcius (°C)	Fahrenheit (°F)	Defrosting (min.)	Operation time (min.) between each defrost cycle	Defrosting (min.)	Operation time (min.) between each defrost cycle
-5	23	9	60	10	30
-15	5	9	32	10	20
-27	-17	9	20	10	15

NOTE: THE SOLO AND DUO PERFORMANCE CHARTS ARE LISTED ON THE SPECIFICATION SHEETS OF THESE UNITS. VISIT OUR WEBSITE AT WWW.VENMAR.CA TO ACCESS THOSE DOCUMENTS.

4. Technical Data (cont'd)

4.4 DIMENSIONS

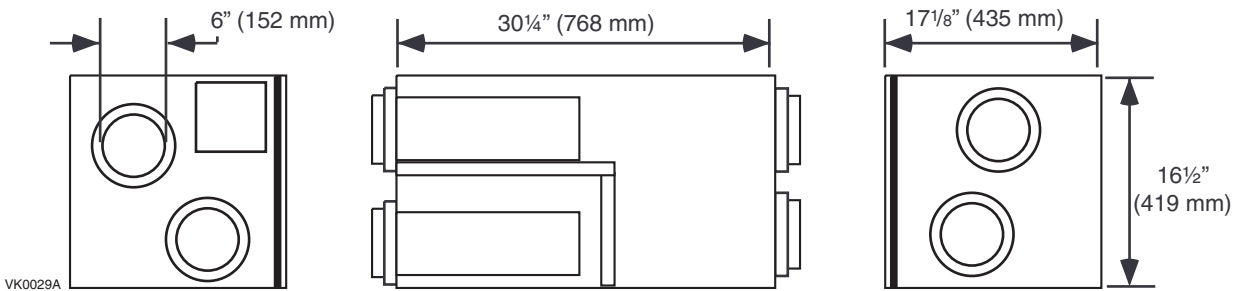

4.5 CONTROLS AND LINK OPTIONS

Main controls:

- Altitude
- Venta

Optional controls:

- 20/40/60-minute push-button timer
- 60-minute crank timer
- Dehumidistat

Link option:

- Furnace interlock
(used with forced air systems)

4.6 SPECIFICATIONS

Model	Solo 1.5	Solo 2.0	Duo 1.2	Duo 1.4	Duo 1.9
Weight	65 lb (29.5 kg)	67 lb (30.4 kg)	71 lb (32.2 kg)	71 lb (32.2 kg)	73 lb (33.1 kg)
Port Diameter	6" (152 mm)	6" (152 mm)	6" (152 mm)	6" (152 mm)	6" (152 mm)
Drain Diameter	1/2" (12 mm)	1/2" (12 mm)	N/A	N/A	N/A
Installation	Chains and springs (provided with the unit).				
Motor Speed	High and low speed factory set (optional increased or decreased low speed)				
Electrical supply	120 V, 60 Hz	120 V, 60 Hz	120 V, 60 Hz	120 V, 60 Hz	120 V, 60 Hz
Power Consumption	150 watts	240 watts	160 watts	160 watts	250 watts

5. Typical Installations

**Installations may vary according to the model number and the position (normal or reverse) in which the unit is installed.*

There are three (3) common installation methods.

5.1 FULLY DUCTED SYSTEM

(Primarily for homes with radiant hot water or electric baseboard heating. See figure 1.)

Moist, stale air is exhausted from the high humidity areas in the home, such as bathrooms, kitchen and laundry room. Fresh air is supplied to bedrooms and principal living areas.

If required, bathroom fans and a range hood may be used to better exhaust stale air.

Homes with more than one level require at least one exhaust register at the highest level.

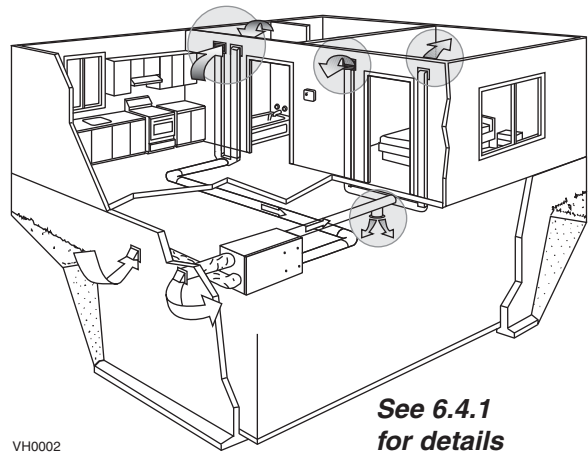

figure 1

5.2 EXHAUST DUCTED SYSTEM (SOURCE POINT VENTILATION)

(For homes with forced air heating. See figure 2.)

Moist, stale air is exhausted from the high humidity areas in the home, such as bathrooms, kitchen and laundry room. Fresh air is supplied to the cold air return or the supply duct of the furnace. If required, bathroom fans and a range hood may be used to better exhaust stale air.

Homes with more than one level require at least one exhaust register at the highest level.

NOTE: For this type of installation, it is not essential that the furnace blower runs when the unit is in operation, but we recommend it.

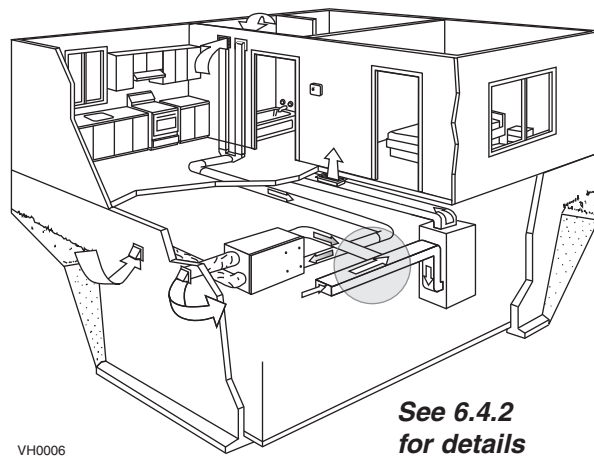

figure 2

5.3 SIMPLIFIED (VOLUME VENTILATION)

(For homes with forced air heating. See figure 3.)

Fresh air and exhaust air flow through the furnace ducts which simplifies the installation.

The use of bathroom fans and a range hood is suggested to exhaust stale air.

NOTE: For this type of installation, the **furnace blower should be running** when the unit is in operation.

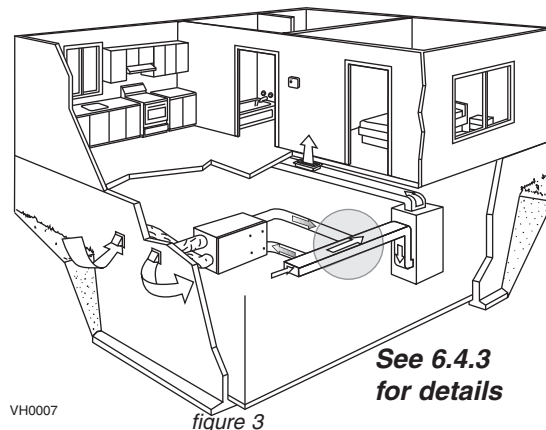

figure 3

6. Installation

⚠ WARNING

When applicable local regulation comprises more restrictive installation and/or certification requirements, the aforementioned requirements prevail on those of this document and the installer agrees to conform to these at his own expenses.

⚠ WARNING

When performing installation, servicing or cleaning the unit, it is recommended to wear safety glasses and gloves.

INSPECT THE CONTENTS OF THE BOX

- Inspect the **exterior of the unit** for shipping damage. Ensure that there is no damage to the door, door latches, door hinges, dampers, duct collars, cabinet, etc.
- Inspect the **interior of the unit** for damage. Ensure that the fan motor assembly, recovery module, insulation, dampers, damper actuator and condensation tray (Solo) are all intact.
- If the unit was damaged during shipping, contact your local distributor. (Claim must be made within 24 hours after delivery.)
- Use checklist included with the unit to ensure that no parts are missing.

6.1 LOCATING AND MOUNTING THE UNIT

NOTE: Please note that the unit can be installed in either the “normal” or “reverse” (upside down) position.

Choose an **appropriate location** for the unit:

- Within an area of the house where the temperature is above 10°C / 50°F (basement, attic, furnace room, laundry room, etc.).
- Away from living areas (dining room, living room, bedroom), if possible.
- So as to provide easy access to the interior cabinet and to the control panel on the side of the unit.
- Close to an exterior wall, so as to limit the length of the insulated flexible duct to and from the unit.
- Close to a drain. If no drain is close by, use a pail to collect run-off. (Solo models only.)
- Away from hot chimneys, electrical panel and other fire hazards.
- Allow for a power source (standard outlet).

Hang the unit with the 4 chains and springs provided (see figures 4 and 5).

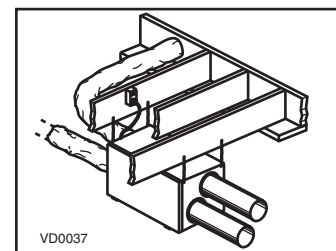

figure 4

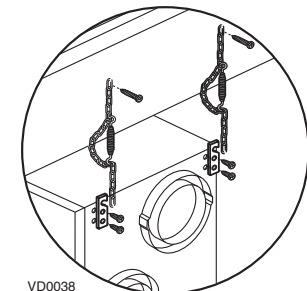

figure 5

CAUTION

Make sure the unit is level, with a 1/8” (3 mm) tilt backwards (see figure 6).

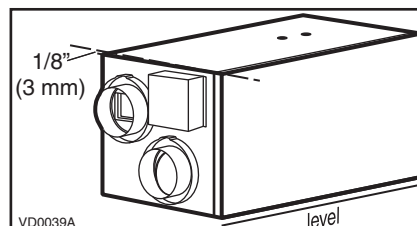

figure 6

6.2 PLANNING OF THE DUCTWORK

- Follow the instructions in Section 6.3 next page to determine the appropriate duct diameters for your system.
- Keep it simple. Plan for a minimum number of bends and joints. Keep the length of insulated duct to a minimum.
- Do not use wall cavities as ducts. Do not use branch lines smaller than 4” Ø (102 mm Ø).
- Do not ventilate crawl spaces or cold rooms. Do not attempt to recover the exhaust air from a dryer or a range hood. This would cause clogging of the recovery module. Use sheet metal for the kitchen exhaust duct.
- Be sure to plan for at least one exhaust register on the highest lived-in level of the house if it has 2 floors or more.

6. Installation (cont'd)

6.3 CALCULATING THE DUCT SIZE

Use the table below to ensure that the ducts you intend to install will be carrying air flows at or under the recommended values. Avoid installing ducts that will have to carry air flows near the maximum values and never install a duct if its air flow exceeds the maximum value.

Duct Diameter	Recommended Air Flow			Maximum Air Flow		
	cfm	l/s	m ³ /h	cfm	l/s	m ³ /h
4" (102 mm)	40 cfm	19 l/s	68 m ³ /h	60 cfm	28 l/s	102 m ³ /h
5" (127 mm)	75 cfm	35 l/s	127 m ³ /h	110 cfm	52 l/s	187 m ³ /h
6" (152 mm)	120 cfm	57 l/s	204 m ³ /h	180 cfm	85 l/s	306 m ³ /h
7" (178 mm)	185 cfm	87 l/s	314 m ³ /h	270 cfm	127 l/s	459 m ³ /h
8" (203 mm)	260 cfm	123 l/s	442 m ³ /h	380 cfm	179 l/s	645 m ³ /h

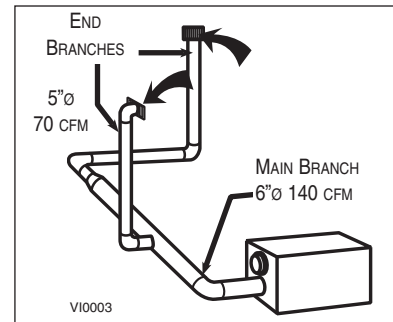

figure 7

NOTE: Examples 6.3.1 and 6.3.2 use imperial measures. The same calculation applies to metric measures.

6.3.1 Example of calculation:

Problem: My installation requires two exhaust registers (one for the kitchen, one for the bathroom). I will connect these registers to a main duct which will connect to the unit (high speed performance value of 140 cfm). What size of duct should I use for the main exhaust duct and for the two end branches leading to the registers? (See figure 7.)

Solution: Simplified method. (For a more detailed method of calculating duct size refer to the ASHRAE or HRAI HANDBOOK).

Main duct: Table above indicates a 6" Ø duct: Recommended air flow: 120 cfm; maximum air flow: 180 cfm. The high speed air flow of 140 cfm is close enough to the recommended value (120) and far enough away from the maximum value (180). Therefore a 6" Ø duct or larger is an appropriate choice for the main exhaust duct.

End branches: Each end branch will have to transport an air flow of 70 cfm (140 divided by 2). Table above indicates a 5" Ø duct: Recommended air flow: 75 cfm; maximum air flow: 110 cfm. The high speed air flow of 70 cfm is close enough to the recommended value (75) and far enough away from the maximum value (110). Therefore a 5" Ø duct or larger is an appropriate choice for the 2 end branches.

NOTE: A 4" Ø duct would have been too small because the maximum acceptable value for a 4" Ø duct is 60 cfm.

6.3.2 Example of a design for a fully ducted system for a unit having a high speed performance of 222 cfm (see figure 8).

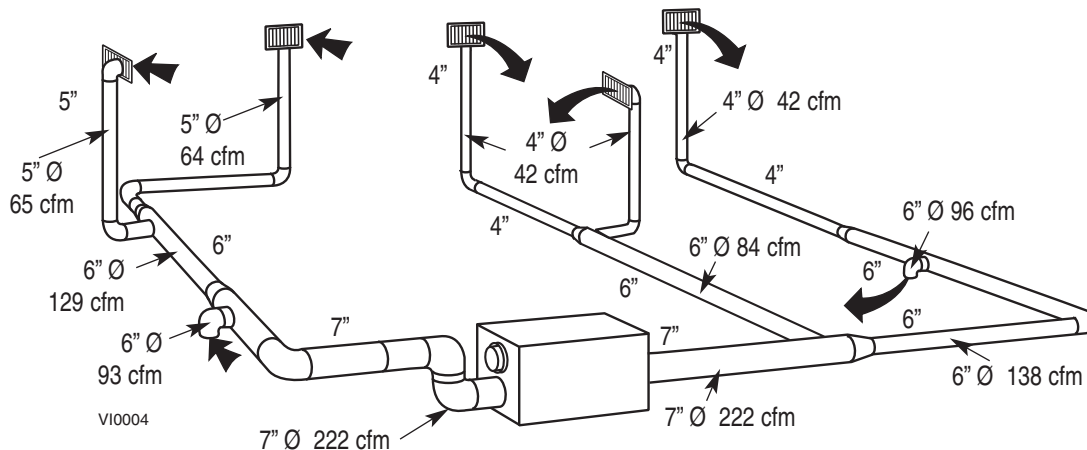

figure 8

6. Installation (cont'd)

6.4 INSTALLING THE DUCTWORK AND REGISTERS

WARNING

Never install a stale air exhaust register in a room where there is a combustion device, such as a gas furnace, a gas water heater or a fireplace.

CAUTION

The ductwork is intended to be installed in compliance with all local and national codes that are applicable.

6.4.1 Fully Ducted System (as illustrated in Section 5.1)

Stale air exhaust ductwork:

- Install registers in areas where contaminants are produced: Kitchen, bathrooms, laundry room, etc.
- Install registers 6 to 12 inches (152 to 305 mm) from the ceiling on an interior wall OR install them in the ceiling.
- Install the kitchen register at least 4 feet (1.2 m) from the range.
- If possible, measure the velocity of the air flowing through the registers. If the velocity is higher than 400 ft/min. (122 m/min), then the register type is too small. Replace with a larger one.

Fresh air distribution ductwork:

- Install registers in bedrooms, dining room, living room and basement.
- Install registers either in the ceiling or high on the walls with air flow directed towards the ceiling. (The cooler air will then cross the upper part of the room, and mix with room air before descending to occupant level.)
- If a register must be floor installed, direct the air flow up the wall.

6.4.2 Exhaust Ducted System (Source Point Ventilation) (as illustrated in Section 5.2)

Stale air exhaust ductwork: (same as for Fully Ducted System, described on point 6.4.1)

Fresh air distribution:

WARNING

When performing duct connection to the furnace, installation must be done in accordance with all applicable codes and standards. Please refer to your local building code.

CAUTION

When performing duct connection to the furnace supply duct, this duct must be sized to support the additional airflow produced by the ERV/HRV. Also, use a metal duct. It is recommended that the ERV/HRV is running when the furnace is in operation in order to prevent backdrafting inside ERV/HRV.

There are two methods for connecting the unit to the furnace:

Method 1: Supply side connection

- Cut an opening into the furnace supply duct at least 18 inches (0.5 m) from the furnace.
- Connect this opening to the fresh air distribution port of the HRV/ERV (use **metal duct**, see figure 9).
- Make sure that the HRV/ERV duct forms an elbow inside the furnace ductwork.
- If desired, interlock (synchronize) the furnace blower operation with the HRV/ERV operation. (See Section 8.3).

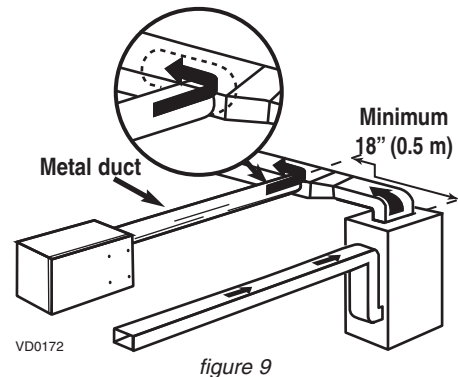

Method 2: Return side connection

- Cut an opening into the furnace return duct not less than 10 feet (3.1m) from the furnace (A+B).
- Connect this opening to the fresh air distribution port of the HRV/ERV (see figure 10).

NOTE: For Method 2, it is not essential that the furnace blower runs when the unit is in operation, but we recommend it. If desired, synchronize the furnace blower operation with the HRV/ERV operation. (See Section 8.3).

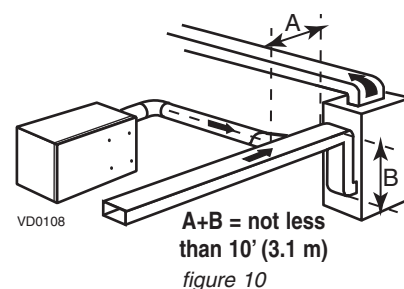

6. Installation (cont'd)

6.4 INSTALLING THE DUCTWORK AND REGISTERS (CONT'D)

6.4.3 Simplified installation (Volume Ventilation) (as illustrated in Section 5.3)

⚠ WARNING

When performing duct connection to the furnace, installation must be done in accordance with all applicable codes and standards. Please refer to your local building code.

CAUTION

When performing duct connection to the furnace ducts (Method 1), these ducts must be sized to support the additional airflow produced by the ERV/HRV. Also, the supply duct must be a metal duct. It is recommended that the ERV/HRV is running when the furnace is in operation in order to prevent backdrafting inside ERV/HRV.

There are two methods (figures 11 and 12) for connecting the unit to the furnace:

Method 1: return-supply

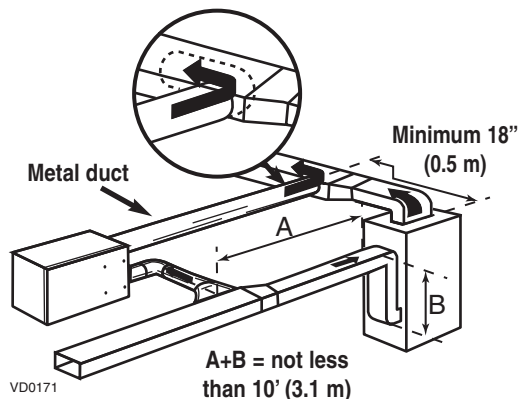

figure 11

Method 2: return-return

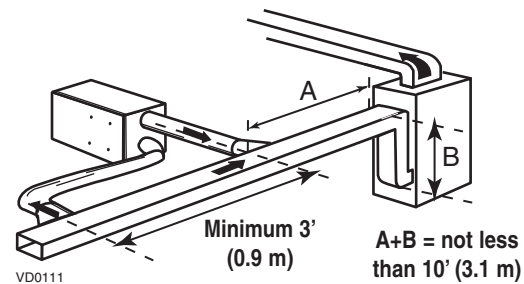

figure 12

Stale air intake:

- Cut an opening into the furnace return duct (not less than 10 feet (3.1 m) from the furnace).
- Connect this opening to the stale air intake port on the HRV/ERV as shown.

Fresh air distribution: (same instructions as for Method 1 or Method 2, Section 6.4.2).

CAUTION

If using Method 2, make sure the furnace blower operation is synchronized with the unit operation! See Section 8.3.

For Method 2 (return-return) make sure there is a distance of at least 3 feet (0.9 m) between the 2 connections to the furnace.

NOTE: For Method 1, it is not essential to synchronize the furnace blower operation with the unit operation, but we recommend it.

6. Installation (cont'd)

6.5 CONNECTING THE DUCTS TO THE UNIT

Insulated flexible duct

Use the following procedure for connecting the insulated flexible duct to the ports on the unit (exhaust to outside and fresh air from outside).

- Pull back the insulation to expose the flexible duct.
- Connect the interior flexible duct to the port using a duct tie.
- Carefully seal the connection with duct tape.
- Pull the insulation over the joint and tuck it between the inner and outer rings of the double collar.
- Pull the vapor barrier over the insulation and over the outer ring of the double collar.
- Apply duct tape to the joint making an airtight seal. Avoid compressing the insulation when you pull the tape tightly around the joint. Compressed insulation loses its R value and causes water dripping due to condensation on the exterior surface of the duct.

CAUTION

Make sure that the vapor barrier on the insulated ducts does not tear during installation to avoid condensation within the duct.

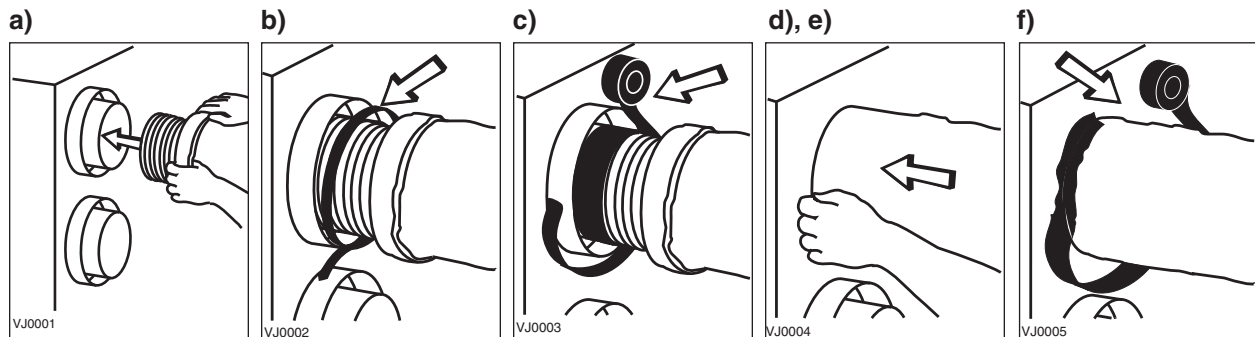

Rigid duct

Use duct tape to connect the rigid ducts to the ports.

CAUTION

Do not use screws to connect rigid ducts to the ports.

Make sure that the 2 balancing dampers are left in a fully open position before connecting the ducts to these ports (fresh air distribution port and stale air exhaust port as shown on figure 13).

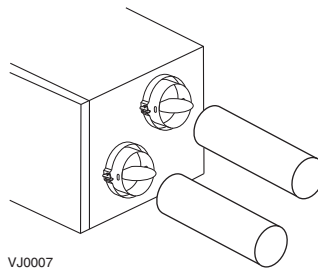

figure 13

6. Installation (cont'd)

6.6 INSTALLING THE EXTERIOR HOODS

Choose an appropriate location for installing the exterior hoods:

- at a minimum distance of 6 feet (1.8 m) between the hoods to avoid cross-contamination
- at a minimum distance of 18 inches (457 mm) from the ground

Make sure the intake hood is at least 6 feet (1.8 m) away from any of the following:

- dryer exhaust, high efficiency furnace vent, central vacuum vent
- gas meter exhaust, gas barbecue-grill
- any exhaust from a combustion source
- garbage bin and any other source of contamination

Refer to figure 14 for connecting the insulated duct to the hoods. Place the "FRESH AIR INTAKE" sticker, provided in the installation kit, on corresponding hood. An "Anti-Gust Intake Hood" should be installed in regions where a lot of snow is expected to fall.

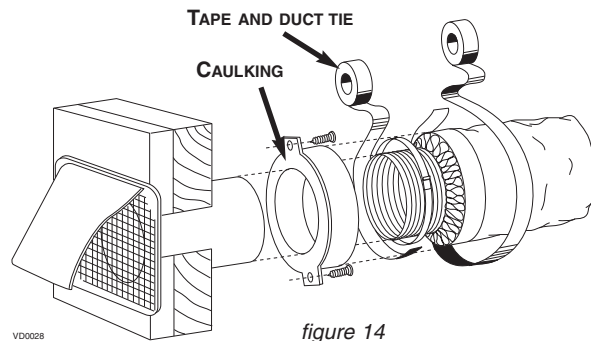
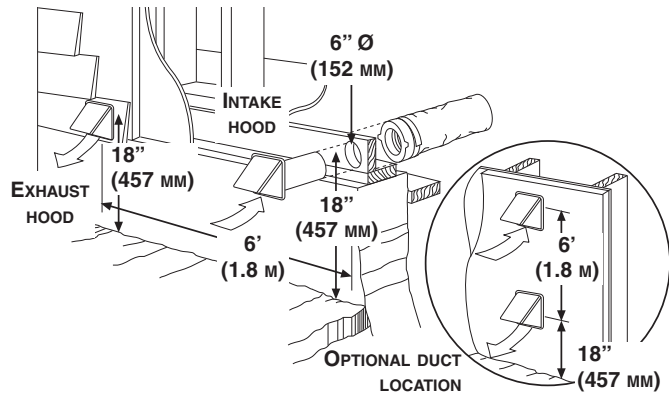
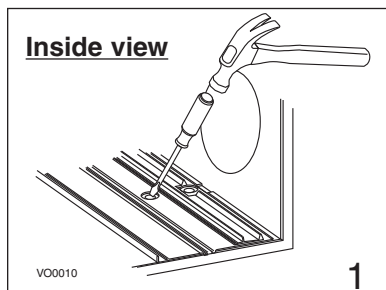
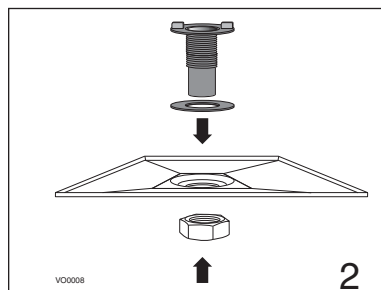

figure 14

6.7 CONNECTING THE DRAIN (SOLO ONLY)



To install the drain fittings, punch the 2 knock-out sections located at the bottom of the unit.



In order to keep the drain pan intact, hand tighten the 2 plastic drain fittings to the unit using the gaskets, washers and nuts as shown.

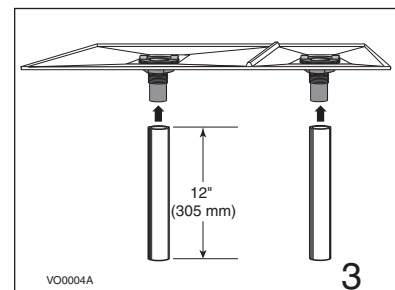

Cut 2 sections of plastic tubing, about 12" (305 mm) long and attach them to each drain fitting.

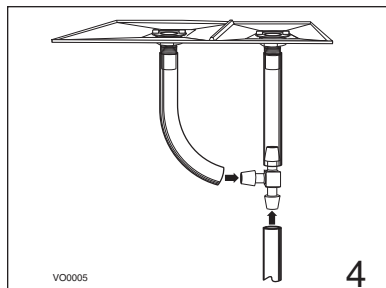

Join the 2 short sections to the "T" junction and main tube as shown.

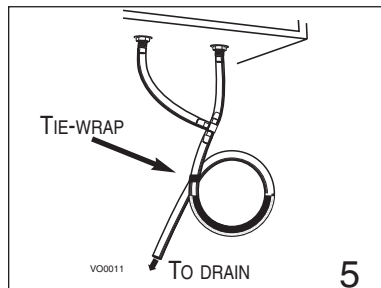

Make a water trap loop in the tube to prevent the unit from drawing unpleasant odors from the drain source. Make sure this loop is situated **BELOW** the "T" as shown. This will prevent water from being drawn back up into the unit in case of negative pressure. Run the tube to the floor drain or to an alternative drain pipe or pail. Be sure there is a slight slope for the run-off.

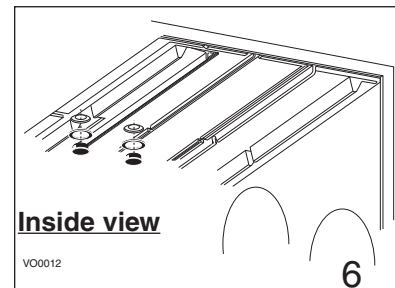

From the inside, install 2 snap bushings on top of the unit. **Do not punch the 2 knock-out sections.**

7. Control Devices

7.1 MAIN CONTROLS

ALTITUDE model

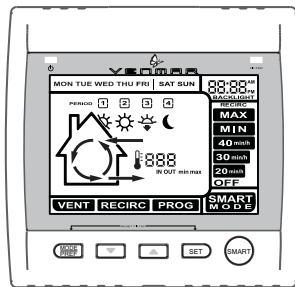

VC0101

VENTA model

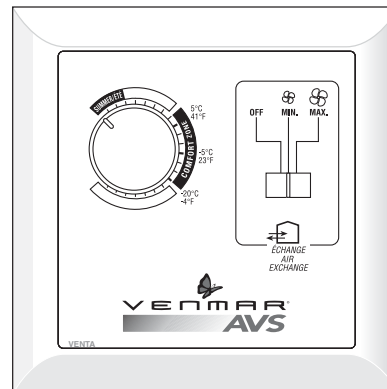

VC0010

MODELS		ALTITUDE	VENTA
MODES	Off Position	X	X
	Intermittent exchange (TBI) 20, 30, 40 min/h	X	
	Low speed continuous exchange	X	X
	High speed continuous exchange	X	X
	Recirculation (manual mode performing air recirculation inside the house)	X	
	Program (programs the desired ventilation according to the period of the day)	X	
	SMART (entirely automatic mode optimizing ventilation)	X	
DETECTOR TYPES	Indoor Temperature	X	
	Outdoor Temperature	X	
INDICATORS	Mode indicator	X	
	Unit status	X	
	Speed indicator	X	
	Maintenance indicator	X	
	Day and Hour indicators	X	
SWITCHES	Sliding button		X
	Push-button	X	

7.2 OPTIONAL CONTROLS

20/40/60-MINUTE PUSH-BUTTON TIMER:

This remote illuminated switch is typically installed in bathrooms, kitchen and laundry room to provide 20, 40 or 60 minutes of high speed ventilation at the push of a button.

60-MINUTE CRANK TIMER:

This timer allows up to 60 minutes of high speed operation to be selected from a remote location.

DEHUMIDISTAT:

This optional control helps control maximum humidity level during fall, winter and spring. You will find a relative humidity % scale meant to reduce the window condensation problems.

7. Control Devices (cont'd)

7.3 OTHER FEATURES

FURNACE INTERLOCK (FOR FORCED AIR HEATING SYSTEM)

The furnace can be interlocked so that it will run simultaneously with the ERV or HRV to ensure proper distribution of fresh air throughout the house.

PERMANENT MEMORY

Our Altitude control has a default memory feature in the event of a power outage. Even the date of the last service reminder is maintained as a convenience to the homeowner.

NOTE: If the power failure duration is more than 4 hours, the day and hour settings must be reprogrammed.

CONTROL UPGRADES

All controls can be used on any unit, so a Venta control can be upgraded to a Altitude in the future.

8. Installation of the Controls

8.1 DIMENSIONS AND SPECIFICATIONS (MAIN CONTROLS)

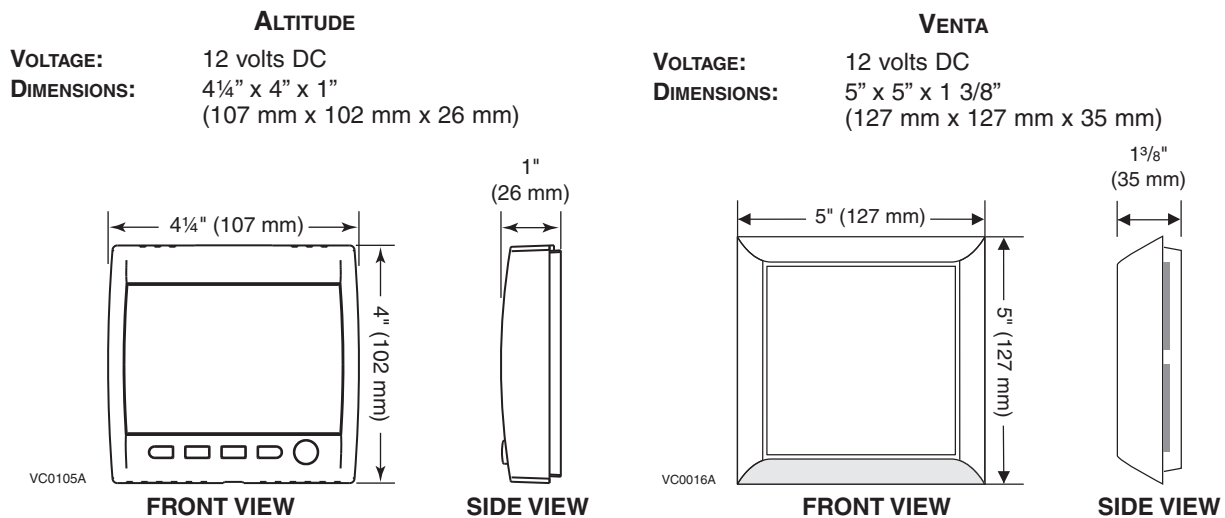

8. Installation of the Controls (cont'd)

8.2 INSTALLATION OF THE MAIN CONTROL

WARNING

Always disconnect the unit before making any connections. Failure in disconnecting power could result in electrical shock or damage of the wall control or electronic module inside the unit.

CAUTION

Failure to comply with the following can cause erratic operation of the unit:

- Never install more than one main wall control per unit.
- Keep control low voltage wiring at least 1 foot (305 mm) away from motors, lighting ballast, light dimming circuit and power distribution panel. Do not route control wiring alongside house power wiring.
- Ensure the wires are securely connected.

8.2.1 Altitude Main Control Installation

1. Route the cable from the unit to a convenient location for the wall control.

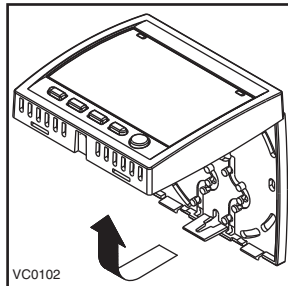

2. Detach the front module from the mounting plate by pulling the bottom part.

3. Run the cable (4 wires) through the central opening of the mounting plate and mount this plate to the wall using screws (not included). If needed, use wall anchors (not included).

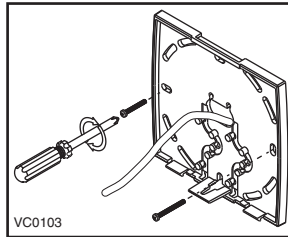

4. Splice back the end of the cable to access the 4 wires. Strip the end of each wire. Connect each wire to its corresponding terminal on the back of the front module: YELLOW wire to "Y", RED wire to "R", GREEN wire to "G" and BLACK wire to "B".

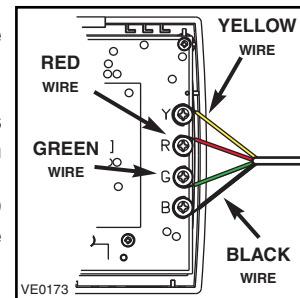

CAUTION

Be careful not to pinch wires when reinstalling the front module on its back plate.

5. Reinstall the front module over the back plate.

8. Installation of the Controls (cont'd)

8.2 INSTALLATION OF THE MAIN CONTROL (CONT'D)

8.2.2 Venta Main Control Installation

1. Route the cable from the unit to the location of the control. The Venta wall control must be installed in a central location on the main floor. Typical locations for this control are kitchen, main hallways and family room.

2. Remove the buttons and the cover plate of the control.

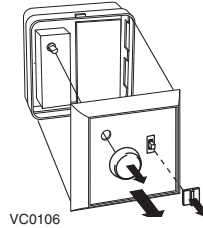

3. Install the wall control 60 inches (1.5 m) from the floor and leave a free space of at least 2 inches (5 cm) to the right of the control to allow user to slide out the control instructions.

Use the template provided in the control box to position the wire hole and the screw holes. Use the screws and the plastic anchors provided in the installation kit to secure the control.

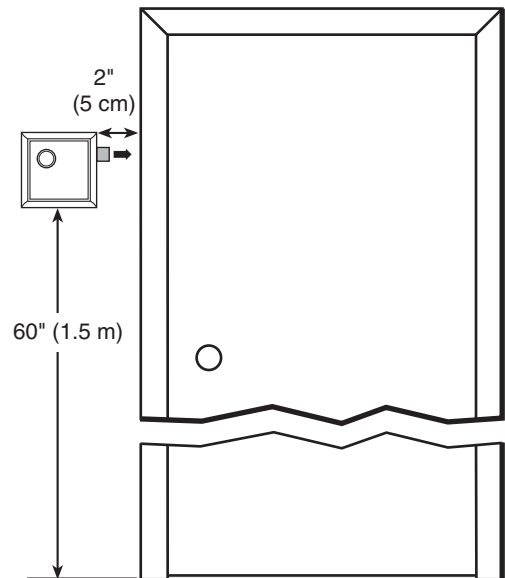

4. Connect the wires to the main control.

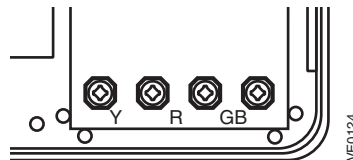

5. Make sure the instruction pull-out is in the occupant's language. If not, turn it to the other side.

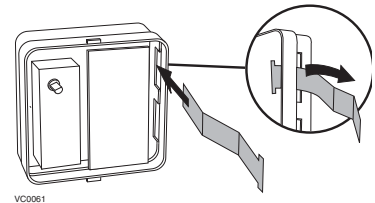

6. Re-install the cover plate and the buttons.

8. Installation of the Controls (cont'd)

8.2 INSTALLATION OF THE MAIN CONTROL (CONT'D)

8.2.3 Main Control Electrical Connection

1. Connect the wires to their corresponding position inside the electrical compartment. Make sure the connections of the unit and of the wall control correspond exactly.

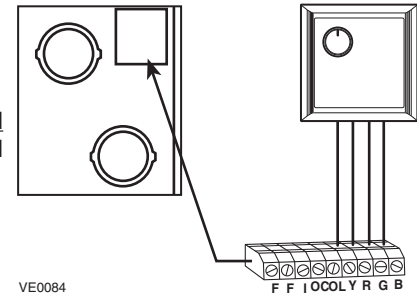

2. Connect the optional controls (if applicable) by referring to section 8.3.
3. Do the appropriate connection to the furnace (if applicable) by referring to Section 8.4.
4. NOTE: If you are in a cold region (zone A or B, as defined in Section 3), set up “extended defrost” by removing jumper JU1F on the main circuit board inside the electrical compartment (see Section 9).
5. Plug in the unit and do the “overall verification” of the system as described in Section 11.

8.3 OPTIONAL CONTROLS ELECTRICAL CONNECTION

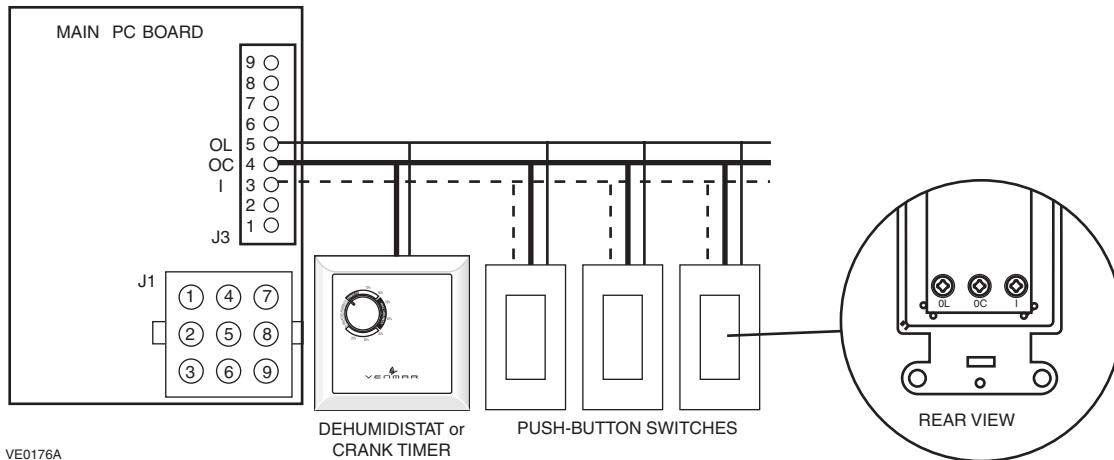

8. Installation of the Controls (cont'd)

8.4 ELECTRICAL CONNECTION TO THE FURNACE

⚠ WARNING

Never connect a 120-volt AC circuit to the terminals of the furnace interlock (standard wiring). Only use the low voltage class 2 circuit of the furnace blower control.

For a furnace connected to cooling system:

On some older thermostats, energizing the “R” and “G” terminals at the furnace has the effect of energizing “Y” at the thermostat and thereby turning on the cooling system. If you identify this type of thermostat, you must use the “alternate furnace interlock wiring”. An additional control relay will then have to be installed.

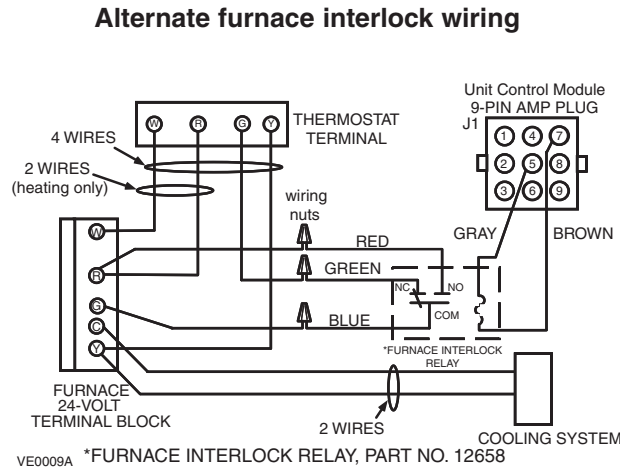
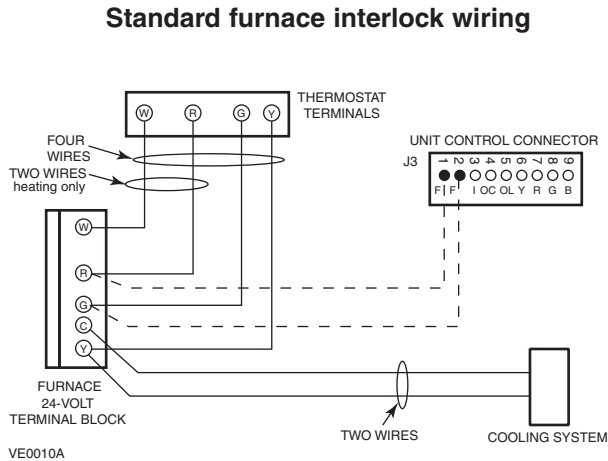

8.5 FURNACE INTERLOCK TYPES

The new TII (*Timed Intermittent Interlock*) function consists in 2 modes: the standard mode and the special mode. Therefore, the electronic board terminal of the Solo and Duo units has now 2 additional jumpers installed across C and D terminals.

STANDARD MODE

The standard mode is the default mode (the interlock function stay as it was). On standard mode, the jumper positions on terminal C and D keep them non-active:

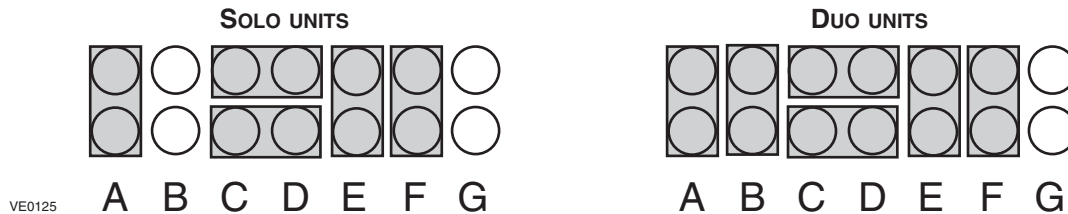

SPECIAL MODE

The special mode drives the furnace interlock relay independently than the HRV/ERV operation. The K4 relay is activated for 10 minutes, and then is deactivated for a 20-minute period, no matter the HRV/ERV command, even if the HRV/ERV is stopped. To perform the special mode, unplug the unit and change the jumper locations as shown below:

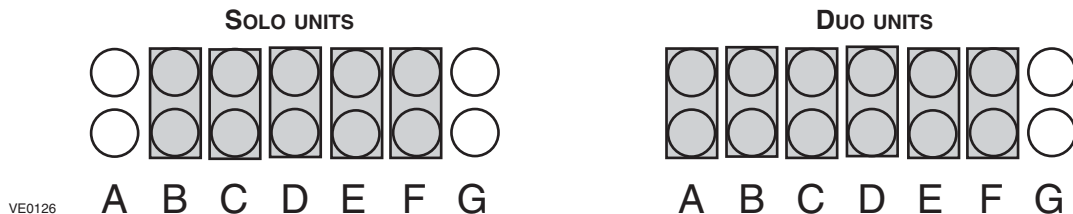

NOTE: For both Solo and Duo units, C and D terminals are now activated.

9. Wiring Diagrams (cont'd)



WARNING

Risk of electrical shocks. Before performing any maintenance or servicing, always disconnect the unit from its power source. This product employs overload protection (fuse). A blown fuse indicates an overload or short-circuit situation. If the fuse blows, unplug the product from the outlet. Replace the fuse as per the servicing instructions (follow product marking for proper fuse rating) and check the product. If the replacement fuse blows, a short-circuit may be present and the product should be discarded or returned to an authorized service facility for examination and/or repair.

Logic

Connection

Models: DUO 1.2, 1.4 and 1.9

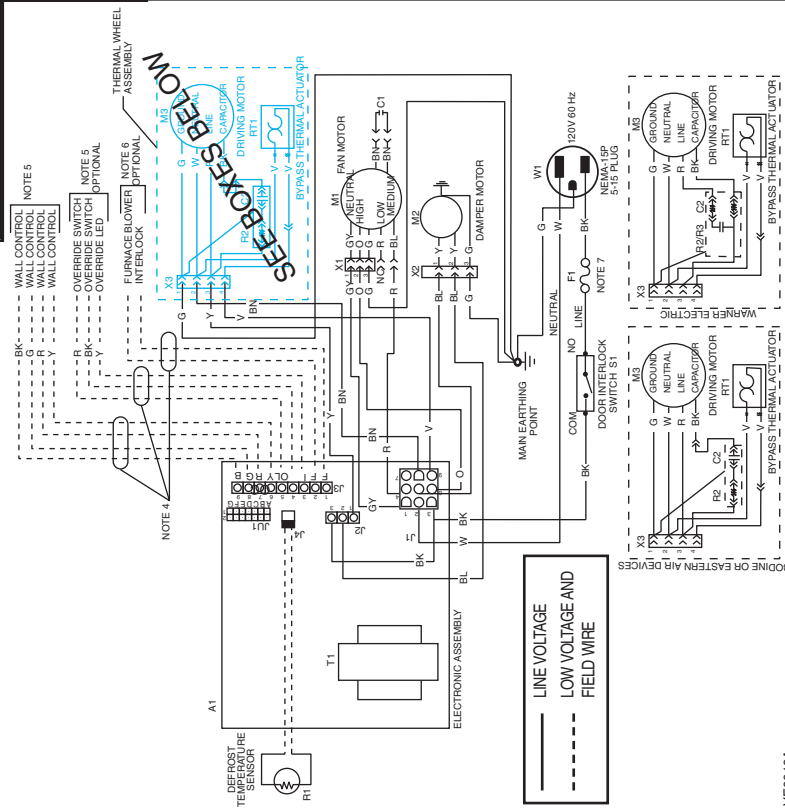

- NOTES**
- Controls available. See Section 8.0. (Low voltage only 12VDC)
 - Factory set wiring for blower speed selection is high and medium. Low speed can be selected instead of medium speed. Disconnect the RED wire from the motor BLUE tap and connect it to the motor RED tap.
 - If any of the original wire, as supplied, must be replaced, use the same or equivalent wire.
 - Use factory supplied protective tubing.
 - Field wiring must comply with applicable codes, ordinances and regulations.
 - Furnace fan circuit must be class 2 circuit only.
 - SPECIFIED UL LISTED CERTIFIED LINE FUSE.** Little Fuse (225.003), 2AG Fast-Acting Fuse, 224/225 Series, Rating: 3A.

DRIVING MOTOR CAPACITOR	DRIVING MOTOR RESISTOR	DRIVING MOTOR	COLOR CODE
1.7 uF, 250 VAC	300 Ohms, 7W	Bodine	BK BLACK
1 uF, 330 VAC	400 Ohms, 10W	Eastern Air Devices	BL BLUE
1 uF, 250 VAC	800 Ohms, 8W	Wärmer Electric	BN BROWN
			R RED
			G GREEN-YELLOW
			W WHITE
			Y YELLOW
			NC NO CONNECTION
			OR ORANGE

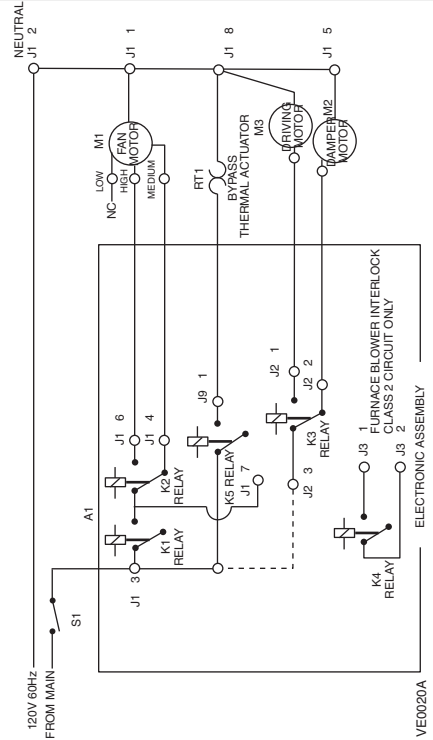

JUMPERS TABLE

		JU1							MODEL								
		A B C D E F G															
JU1A	JU1B	JU1C	JU1D	JU1E	JU1F	JU1G											
IN	OUT	IN	OUT	IN	OUT	IN	OUT	IN	OUT	IN	OUT	IN	OUT	IN	OUT	IN	OUT
IN	IN	IN	IN	IN	IN	IN	IN	IN	IN	IN	IN	IN	IN	IN	IN	IN	IN
IN	IN	IN	IN	IN	IN	IN	IN	IN	IN	IN	IN	IN	IN	IN	IN	IN	IN
IN	IN	IN	IN	IN	IN	IN	IN	IN	IN	IN	IN	IN	IN	IN	IN	IN	IN

STANDARD MODE 43700, 45700, 43710
 STANDARD MODE EXTENDED DEFROST
 SPECIAL MODE 43700, 45700, 43710
 SPECIAL MODE EXTENDED DEFROST

FUNCTION TABLE

MODE	RELAY					DEFROST
	K1 & K4*	K2	K3	K5		
Intermittent	0	0	0	0	0	
Continuous Low	1	0	1	0	0	
Continuous High	1	1	1	0	0	K5 active only (-15°C-T+10°C)
Circulation Low	1	0	0	0	0	
Circulation High	1	1	1	0	0	
Defrost Cycle	1	1	0	0	0	STANDARD
						EXTENDED
						-5°C
						10/30 min
						-15°C
						9/32 min
						-27°C
						10/20 min
						10/15 min

0 = Relay coil is de-energized
 1 = Relay coil is energized
 * On special mode, K4 is cycling 10 min. ON and 20 min. OFF

10. Air Flow Balancing

WHAT YOU NEED TO BALANCE THE UNIT

- A magnehelic gauge capable of measuring 0 to 0.5 inch of water (0 to 125 Pa) and 2 plastic tubes.
- The balancing chart provided with the unit.

PRELIMINARY STAGES TO BALANCE THE UNIT

- Seal all the unit ductwork with tape. Close all windows and doors.
- Turn off all exhaust devices such as range hood, dryer and bathroom fans.
- Make sure the balancing dampers are **fully open**.
- Make sure all filters are clean (if it is not the first time you balance the unit).

BALANCING PROCEDURE

1. Set the unit to high speed:

Make sure that the furnace blower is ON if the installation is in any way connected to the ductwork of the cold air return. If not, leave furnace blower OFF. If the outside temperature is below 0°C / 32°F, make sure the unit is not running in defrost while balancing. (By waiting 10 minutes after plugging the unit in, you are assured that the unit is not in a defrost cycle.) **Disconnect the wire of the bypass damper (Duo only).**

- Place the magnehelic gauge on a level surface and adjust it to zero.
- Connect tubing from gauge to EXHAUST air flow pressure taps (see diagram). Be sure to connect the tubes to their appropriate *high/low* fittings. If the gauge drops below zero, reverse the tubing connections.
NOTE: It is suggested to start with the exhaust air flow reading because the exhaust has typically more restriction than the fresh air, especially in cases of fully ducted installations or source point ventilation. Place the magnehelic gauge upright and level. Record equivalent AIR FLOW of the reading according to the balancing chart.
- Move tubing to FRESH air flow pressure taps (see diagram). Adjust the fresh air balancing damper until the fresh air flow is approximately the same as the EXHAUST air flow. If fresh air flow is less than exhaust air flow, then go back and adjust the exhaust balancing damper to equal the fresh air flow.
- Secure both dampers in place with tape or with a fastening screw.
- Write the required air flow information on a label and stick it near the unit for future reference (date, maximum speed air flows, your name, phone number and business address). **Connect the wire of the bypass damper (Duo only).**

NOTE: The unit is considered balanced even if there is a difference of ± 10 cfm or ± 5 l/s or 17 m³/h between the two air flows.

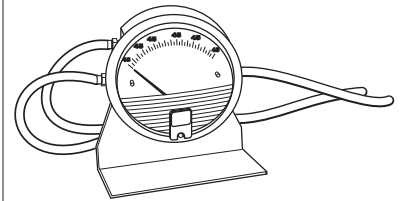

VP0009

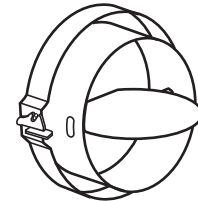

VD0051

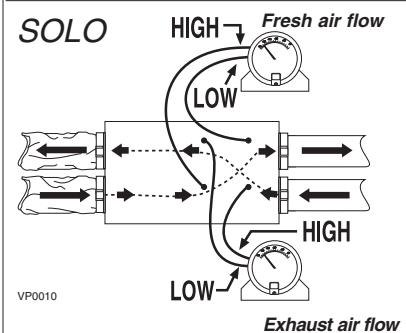

VP0010

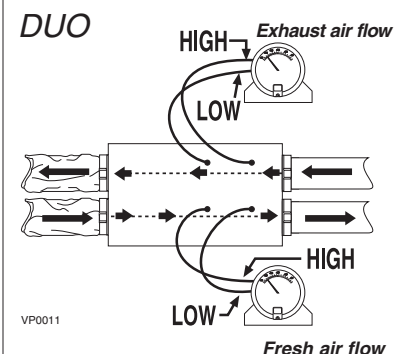

VP0011

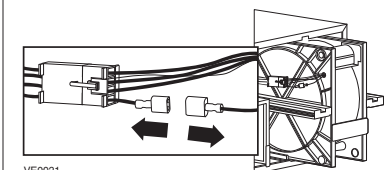

VE0021

NOTE: Always unplug bypass wire while balancing a Duo.

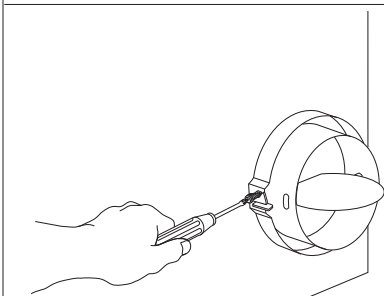

VD0052

11. Overall Verification

11.1 MAIN CONTROLS

This procedure allows the installer to verify that all modes of operation are fully functional.

During the verification of a main control, make sure that all optional remote controls are inactive.

ALTITUDE

At its very start-up, the Altitude wall control will perform a booting sequence before being ready to operate. The booting sequence is done when the hour display is flashing.

Refer to the installation sheet included with the Altitude wall control for more details in programming and setting preferences.

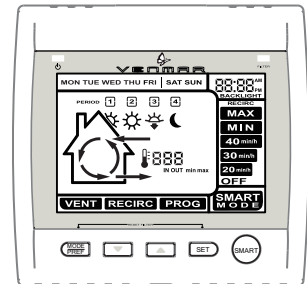

VC0101

VENTA (6 different control scenarios to be tested)

	Set the slider switch to	Set dehumidistat dial to	Results expected fan speed / damper
1	OFF	maximum counterclockwise	motor off / closed
2	OFF	maximum clockwise	motor off / closed
3	MIN.	maximum counterclockwise	low speed / open
4	MIN.	maximum clockwise	high speed / open
5	MAX.	maximum counterclockwise	high speed / open
6	MAX.	maximum clockwise	high speed / open

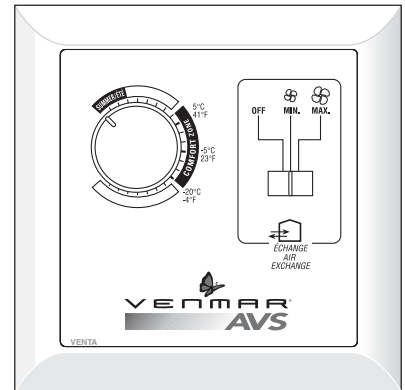

VC0010

11.2 OPTIONAL CONTROLS

First, turn OFF the main control device before checking the remote optional controls.

20/40/60-MINUTE PUSH-BUTTON TIMER:

Activate the push-button. Within 2 seconds, push one time for 20 minutes, two times for 40 minutes or three times for a 60-minute activation.

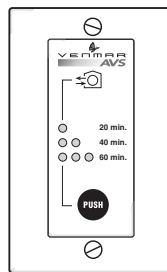

VC0007

Results expected:

1. Motor speed: High for 20, 40 or 60 minutes.
2. Indicator light goes "ON" and flashes every 5 seconds (one time to indicate a 20-minute operation, two times for a 40-minute, and three times for a 60-minute operation).

NOTE: To stop activation, push one more time.

DEHUMIDISTAT:

Turn dial to the maximum clockwise position (20%).

Result expected:

Motor speed changes to high.



VC0009

60-MINUTE CRANK TIMER:

Activate the timer.

Results expected:

Motor speed: High for up to 60 minutes.

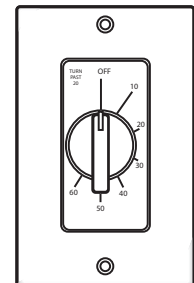

VC0017

12. Maintenance / Instructions for User

⚠ WARNING

Risk of electrical shocks. Before performing any maintenance or servicing, always disconnect the unit from its power source.

- Review with the user the steps required for the regular maintenance of her/his ventilation system. These steps are described in detail in the user manual:

FOUR TIMES A YEAR:

- Inspect the intake hood, and clean if needed.
- Clean the filters.
- Clean the interior of the cabinet and clean the door.
- Clean the condensation tray and inspect the drain tubing (SOLO only).

ONCE A YEAR:

- Clean the recovery module (core or thermal wheel).
- Clean the blades of the blower wheels if needed.

- Warn the user of the necessity to rebalance the system following a major house renovation or following the installation of any extra registers.
- Make sure the user understands how to use the main control as described in the user manual.

CAUTION

Do not oil the motor. It is already permanently lubricated.

13. Troubleshooting

NOTE: Be sure to unplug and inspect the unit before proceeding with these steps.

Problems	Possible causes	You should try this
1. The error code E1 is displayed on Altitude wall control screen.	<ul style="list-style-type: none"> The wires may be in reverse position. The wires may be broken. The wires may have a bad connection. 	<ul style="list-style-type: none"> Ensure that the color coded wires have been connected to their appropriate places. Inspect every wire and replace any that are damaged. Ensure the wires are correctly connected.
2. There is no outside temperature displayed on Altitude wall control screen ■■■■■	<ul style="list-style-type: none"> The unit thermistor is defective. 	<ul style="list-style-type: none"> Replace the unit thermistor. <p>NOTE: At its very start-up or after a power failure, it takes some minutes before the outside temperature appears on screen. The delay duration depends on which operation mode the wall control is set. The shortest delay is obtained when the wall control is set on MIN or MAX in VENT Mode.</p>
3. Altitude wall control screen alternates between normal display and E3.	<ul style="list-style-type: none"> The Altitude wall control is defective. 	<ul style="list-style-type: none"> Replace the Altitude wall control.
4. Altitude wall control screen alternates between normal display and E4.	<ul style="list-style-type: none"> The Altitude wall control is defective. 	<ul style="list-style-type: none"> Replace the Altitude wall control.
5. Unit doesn't work.	<ul style="list-style-type: none"> The circuit board may be defective. The power cord fuse may be blown. 	<ul style="list-style-type: none"> Unplug the unit. Disconnect the main control and the optional(s) control(s) (if need be). Jump B and G terminals. Plug the unit. If the motor runs on high speed and the damper opens, the circuit board is not defective. Unplug the unit. Unscrew the fuse holder (grey circle on illustration beside). Check if the fuse is blown (the strand is broken). If it is blown, replace the fuse according to the specifications on the unit power cord tag.

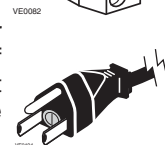
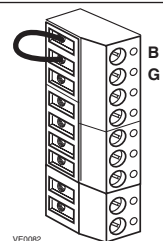

13. Troubleshooting (cont'd)

Problems	Possible causes	You should try this
6. The damper actuator does not work.	<ul style="list-style-type: none"> The 9-pin connector may have a loose connection. The damper actuator may be defective. The circuit board may be defective. 	<ul style="list-style-type: none"> Unplug the unit and check to make sure all the crimp connections are secured. Check the damper actuator connections as well. Feed 120 V directly to the damper actuator. If the problem persists, replace the damper actuator. Replace the circuit board if the problem is not solved by the above.
7. The wall control does not work.	<ul style="list-style-type: none"> The wires may be in reverse position. The wires may be broken. There may be a short-circuit. The wire in the wall OR the wall control may be defective. The circuit board may be defective. 	<ul style="list-style-type: none"> Ensure that the color coded wires have been connected to their appropriate places. Inspect every wire and replace any that are damaged. With the help of a multimeter, check for continuity. Jump "B" and "G" (BLACK and GREEN). If unit switches to high speed, remove the wall control and test it right beside the unit using another shorter wire. If the wall control works there, change the wire. If it doesn't, change the wall control. If the unit does not switch to high speed, replace the circuit board.
8. The Dehumidistat does not work OR the 20/40/60-min. push-button timer does not work OR its indicator light does not stay on.	<ul style="list-style-type: none"> The Dehumidistat OR push-button may be defective. 	<ul style="list-style-type: none"> Jump the OL and OC terminals. If the unit switches to high speed, remove the Dehumidistat or push-button and test it right beside the unit using another shorter wire. If it works there, change the wire. If it doesn't, change the Dehumidistat or the push-button.
9. The defrost cycle does not work (the fresh air duct is frozen OR the fresh air distributed is very cold.	<ul style="list-style-type: none"> Ice deposits may be hindering the damper operation. The damper rod or the port damper itself may be broken. The damper actuator may be defective. The circuit board may be defective. The thermistor may be defective. 	<ul style="list-style-type: none"> Remove the ice. Inspect these parts and replace if necessary. Plug in the unit and select "MIN" or "MAX". Press the door switch and see if the port damper opens. If it doesn't open, feed 120V directly to the damper actuator. If the port damper still doesn't open, replace the damper actuator. Unplug the unit. Unplug the defrost sensor wire (see J4 on electrical diagram Section 9). Plug the unit back in. Select "MIN" and make sure the unit is adjusted for low speed operation (turn all Humidity Controls maximum counterclockwise). Wait 3 minutes. The unit should switch to high speed and the damper at the fresh air intake port should close (defrost mode). If this doesn't happen, then replace the circuit board. If the defrost mode works well after having disconnected the thermistor wire (above test), this means the thermistor is probably defective. You should replace it.

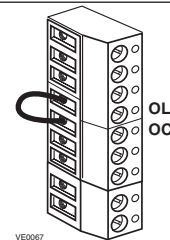

14. References

- HVI, "Installation Manual for Heat Recovery Ventilators", 1987 edition.
- ASHRAE 1984 Systems Handbook, chapter 11, "Air Distribution Design for Small Heating and Cooling Systems".

