

Installation and User Manual

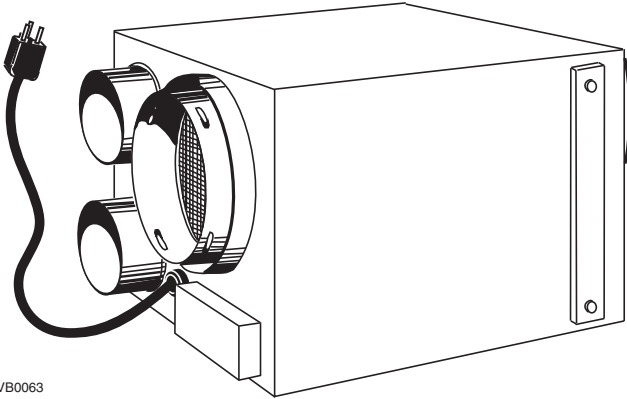

VB0063

AE60/EA 1500/HV 1.5

RESIDENTIAL USE ONLY

READ AND SAVE THESE INSTRUCTIONS

INSTALLER: LEAVE THIS MANUAL WITH THE HOMEOWNER.
HOMEOWNER: USE AND CARE INFORMATION ON
PAGES 20 TO 24.

Address of your installer

WARNING

TO REDUCE THE RISK OF FIRE, ELECTRIC SHOCK, OR PERSONAL INJURY OBSERVE THE FOLLOWING:

1. This unit is intended for residential installation only.
2. Use this unit only in the manner intended by the manufacturer. If you have questions, contact the manufacturer at the address or telephone number listed in the warranty.
3. Before replacing filters, servicing or cleaning unit, disconnect power cord from electrical outlet.
4. Installation must be done in accordance with all applicable codes and standards, including fire-rated construction codes and standards.
5. This unit is not designed to provide combustion and/or dilution air for fuel-burning appliances.
6. When cutting or drilling into wall or ceiling, do not damage electrical wiring and other hidden utilities.
7. Do not use this unit with any solid-state speed control device other than optional controls C34, CMR or ACCGSC3.
8. This unit must be grounded. The power supply cord has a 3-prong grounding plug for your personal safety. It must be plugged into a mating 3-prong grounding receptacle, grounded in accordance with the national electrical code and local codes and ordinances. Do not remove the ground prong. Do not use an extension cord.
9. Do not install in a cooking area or connect directly to any appliances.
10. Do not use to exhaust hazardous or explosive materials and vapors.
11. Do not run any air ducts directly above or closer than 2 ft (0.61 m) to any furnace or its supply plenum, boiler, or other heat producing appliance. Do not connect the unit ducts to the furnace ducts, neither return plenum or supply.
12. When performing installation, servicing or cleaning the unit, it is recommended to wear safety glasses and gloves.
13. When applicable local regulations comprise more restrictive installation and/or certification requirements, the aforementioned requirements prevail on those of this document and the installer agrees to conform to these at his own expenses.
14. This product employs overload protection (fuse). A blown fuse indicates an overload or short-circuit situation. If the fuse blows, unplug the product from the outlet. Replace the fuse as per the servicing instructions (follow product marking for proper fuse rating) and check the product. If the replacement fuse blows, a short-circuit may be present and the product should be discarded or returned to an authorized service facility for examination and/or repair.

CAUTION

1. To avoid premature clogged filters, turn OFF the unit during construction or renovation.
2. Please read specification label on product for further information and requirements.
3. Be sure to duct air outside – Do not intake/exhaust air into spaces within walls or ceiling or into attics, crawl spaces, or garage.
4. Intended for residential installation only in accordance with the requirements of NFPA 90B.
5. The ductwork is intended to be installed in compliance with all local and national codes that are applicable.
6. Do not use the AE60, EA 1500 or HV 1.5 unit when varnishing. Furthermore, if the unit is installed in the attic, it is highly recommended to block the stale air intake and fresh air register. The varnish vapors may damage the unit.
7. At least once in a year, the unit mechanical and electronic parts should be inspected by qualified service personnel.
8. If the unit is installed in the attic, it should not be turned off during the winter time in order to avoid condensation inside the unit and inside the ducts.
9. During snow/rain storm, operate the unit in recirculation mode to prevent water build up in the ventilator.

TABLE OF CONTENTS

1.	YOUR UNIT AND ITS PURPOSE	4
2.	TYPICAL INSTALLATIONS	5
	2.1 <i>Basement Installation</i>	5
	2.2 <i>Attic Installation</i>	5
	2.3 <i>Mounting Considerations</i>	6
3.	INSTALL THE UNIT	7
	3.1 <i>Locating and Mounting the Unit</i>	7
	3.2 <i>Tools and Materials</i>	7
	3.3 <i>How to Hang the Unit</i>	7
	3.4 <i>Planning of the Ductwork</i>	8
	3.5 <i>Installing 6" Ducts and Registers</i>	8-10
	3.6 <i>Insulated Flexible Ducts Installation</i>	11
	3.7 <i>Exterior Opening(s) Installation</i>	11-17
4.	CONTROL	18
	4.1 <i>Installation of the Control</i>	18-20
	4.2 <i>Operating the Control</i>	20-21
5.	MAINTENANCE	22
	5.1 <i>Biannual Maintenance</i>	22
	5.2 <i>Annual Maintenance</i>	23
	5.3 <i>Master Reset</i>	24
6.	TROUBLESHOOTING	24

ABOUT THIS MANUAL/PRODUCT

The purpose of this guide is to help you to install properly your unit, and to show you how to operate and do the maintenance. Please read completely before starting the installation.

Please note the illustrations are typical ones.

We welcome any suggestions you may have concerning this manual and/or the unit, and we would appreciate hearing your comments on ways to better serve you. Please forward all correspondence to us at the address indicated on the product registration card included with this manual.

This manual uses the following symbols to emphasize particular information:

WARNING

Identifies an instruction which, if not followed, might cause serious personal injuries including possibility of death.

CAUTION

Denotes an instruction which, if not followed, may severely damage the unit and/or its components.

NOTE: Indicates supplementary information needed to fully complete an instruction.

Finally, we want to congratulate you on your purchase of this excellent unit which will allow you and your family to enjoy fresh air throughout your home for years to come!

NOTE: The unit does not require balancing because of its design.

1. YOUR UNIT AND ITS PURPOSE

OPERATIONAL PRINCIPLES

The air exchanger is designed to eliminate problems of excessive humidity, to steady the temperature and the humidity and to filter and purify the air inside your house. The air exchanger carries out the following operations:

AIR RECIRCULATION:

The system recirculates the air inside the house, without exchanging with the outside. This operation steadies the temperature and the humidity throughout.

FILTRATION:

When the air flows through the system, a mechanical filter traps dust particles.

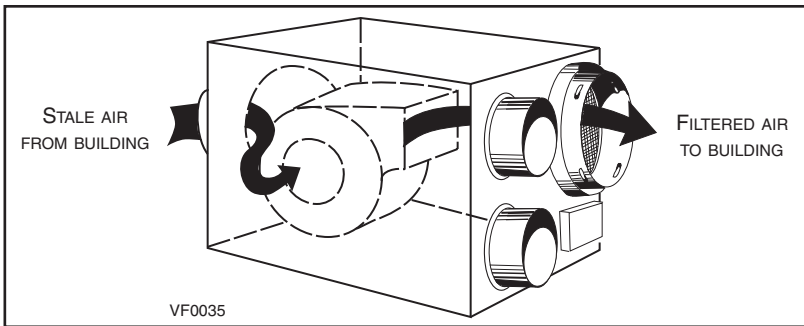

CIRCULATION WITH AIR EXCHANGE:

While continually circulating the air within the house, the unit also evacuates part of this stale air and replaces it with fresh dry air from the outside. The following extra benefits are thus obtained: expelling the excess of humidity during the winter months, ventilate the house on hot summer nights, elimination of stale air.

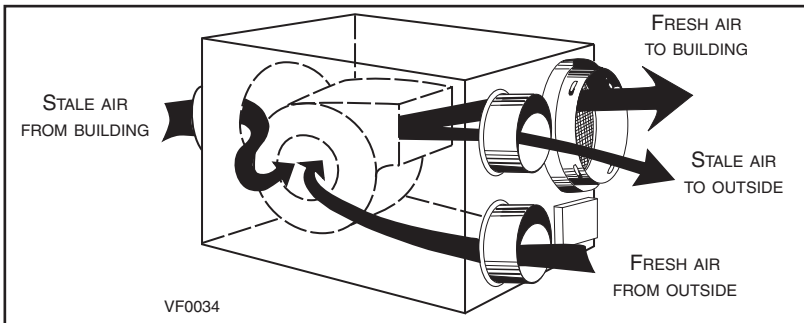

2. TYPICAL INSTALLATIONS

Use the following illustrations as guidelines to help you decide where your unit will be installed. The unit should be hung to the joists, using chains and springs (included). If needed, this unit can be installed upside down. For more details, see Point 3. **INSTALL THE UNIT.**

In every case, bathroom fan and a range hood should be used to exhaust stale air. Also, for homes with more than one level, we recommend one exhaust register at the highest level.

NOTE: An electrical outlet (standard 3-prong grounding outlet) has to be available within 3 feet from the unit.

2.1 BASEMENT INSTALLATION

Only one outside connection is needed when using the Tandem® transition* and the dual outside port*, simplifying the installation. These two components are included in the installation kit no. 15273 (purchase separately).

NOTES: 1. See Point 2.3 **MOUNTING CONSIDERATIONS** on next page for required joists opening.

2. The installation kit no. 15273 is not available in the U.S.A.

*Patented.

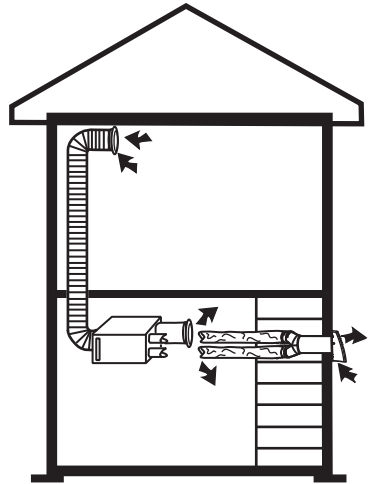

VH0053

2.2 ATTIC INSTALLATION

If the unit is installed in the attic, this unit must always be in operation during the winter season. Use the installation kit no. EA20130 (purchase separately).

NOTE: The installation kit no. EA20130 is not available in the U.S.A.

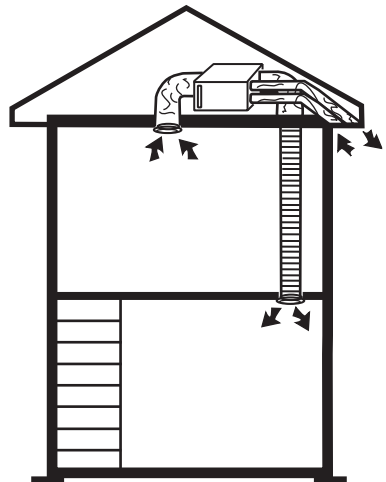

VH0004

2. TYPICAL INSTALLATIONS (CONT'D)

2.3 MOUNTING CONSIDERATIONS

This unit can be used for a retrofit application. Connect the existing ducts to the corresponding unit ports. If the previous stale air to outside duct and fresh air from outside duct are 5" diameter, install the 5" diameter adapters (included) over each of the corresponding unit ports. Also, if using the installation kit no. 15273 or no. EA20130 (not available in the U.S.A.), install these 5" diameter adapters. Use 4 screws (included) per adapter to attach them to the unit. See figure below.

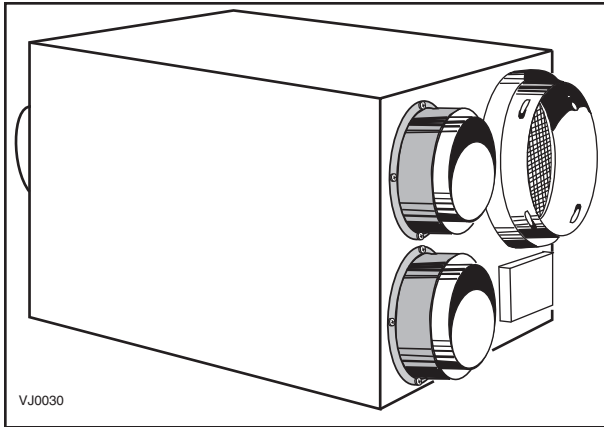

The joists opening needed to install the Tandem transition must be $9\frac{3}{4}$ " (248 mm) minimum. Also, the maximum height of the tandem transition is $8\frac{3}{4}$ " (222 mm). See Tandem transition end view below.

NOTE: The Tandem transition is included in the installation kit no. 15273 (not available in U.S.A.).

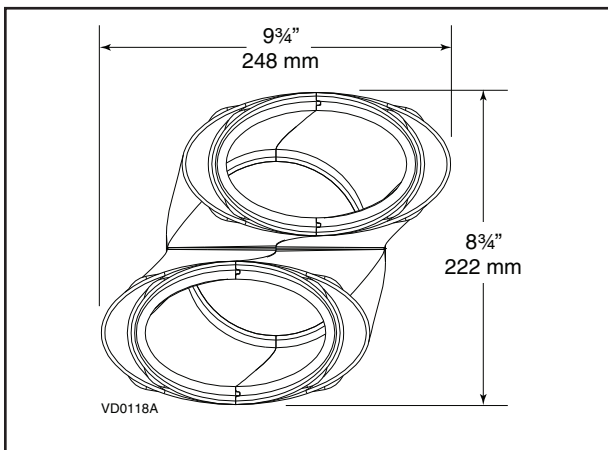

3. INSTALL THE UNIT

3.1 LOCATING AND MOUNTING THE UNIT

Choose an appropriate location for the unit, far from the areas of the house where peace and quiet are desired.

- So as to provide easy access for filter maintenance (sometimes, by installing the unit upside down, it becomes easier to get to the filter).
- Close to an exterior wall, so as to limit the length of the insulated flexible ducts to and from the unit.
- Away from hot chimneys and other fire hazards.
- Allow for a power source (standard 3-prong grounding outlet).

3.2 TOOLS AND MATERIALS

- Phillips or Robertson no. 2 screwdriver
- Scissors or utility knife (to cut duct tape and flexible ducts)
- Duct tape
- Jig saw
- A pair of metal shears (if the exterior covering of the house is aluminum or vinyl)
- A chisel and hammer (if the exterior covering of the house is brick)
- Caulking gun and caulking

3.3 HOW TO HANG THE UNIT

Use the 4 chains and springs in the hardware pack provided with the unit. According to your needs, the unit can be installed upside down.

CAUTION

Make sure the unit is level.

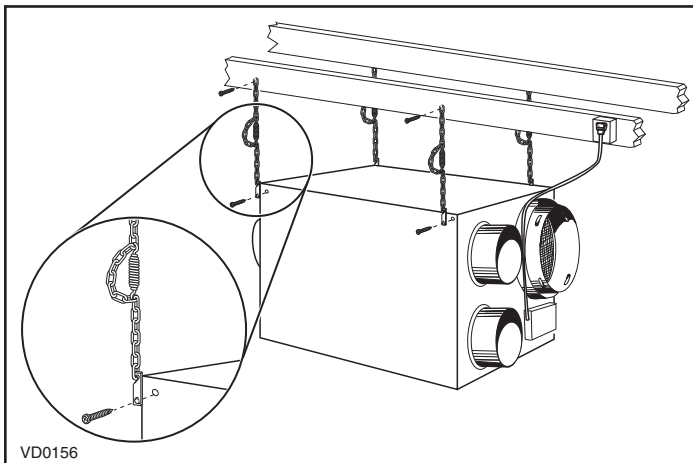

3. INSTALL THE UNIT (CONT'D)

3.4 PLANNING OF THE DUCTWORK

- Keep it simple. Plan for a minimum number of bends and joints. Keep the length of the insulated ducts to a minimum.
- Do not use wall cavities as ducts. Do not use branch lines smaller than 4" (102 mm) diameter.
- Do not ventilate crawl spaces or cold room. Do not attempt to recover the exhaust air from a dryer or a range hood, this would cause the clogging of the unit.
- Be sure to plan at least one exhaust register on the highest lived-in level of the house, if it has 2 floors or more.

3.5 INSTALLING 6" DUCTS AND REGISTERS

CAUTION

If ducts have to go through an unconditioned space, always use insulated ducts (purchase separately).

3.5.1 STALE AIR EXHAUST DUCTWORK

⚠ WARNING

Never install a stale air exhaust register in a room where a combustion device operates, such as a gas water heater, a gas furnace or a fireplace.

- Install the stale air exhaust register(s) in the main area where the contaminants are produced: kitchen, living room, etc. Position the register(s) as far from the stairway as possible and in such a way that the air circulates in all the lived-in spaces in the house.
- If a register is installed in the kitchen, it must be located at least 4 feet (1.2 m) from the range.
- Install the register(s) 6 to 12 inches (152 to 305 mm) from the ceiling on an interior wall OR install it in the ceiling.
- Attach one end of the 6" flexible duct to the stale air exhaust register, and the other end to the unit stale air from building port, using tie wrap and duct tape.

3.5.2 FRESH AIR DISTRIBUTION DUCTWORK

- Install the fresh air distribution register(s) in a large, open area in the lowest level to ensure the greatest possible air circulation. Keep in mind that the fresh air register(s) must be located as far as possible from the stale air register(s).
- Install the register(s) in the ceiling OR 6 to 12 inches (152 to 305 mm) from the ceiling on an interior wall. The duct length should be at least 15' (4.6 m). (The cooler air will then cross the upper part of the room and mix with room air before descending to occupant level.)
- Attach one end of the 6" flexible duct to the fresh air distribution register, and the other end to the unit fresh air to building port, using tie wrap and duct tape.

3. INSTALL THE UNIT (CONT'D)

3.5 INSTALLING 6" DUCTS AND REGISTERS (CONT'D)

3.5.3 SUGGESTED REGISTER LOCATIONS

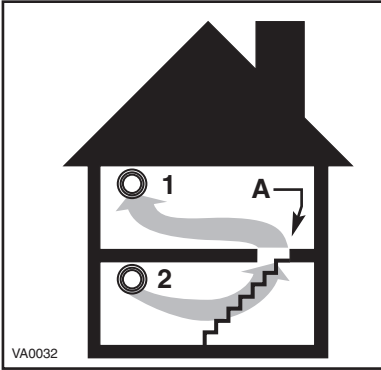

BUNGALOW

Basement stairwell (A): Open, lateral.

One stale air exhaust register (1) in the highest lived-in level of the house and one fresh air distribution register (2) in the lowest lived-in level of the house.

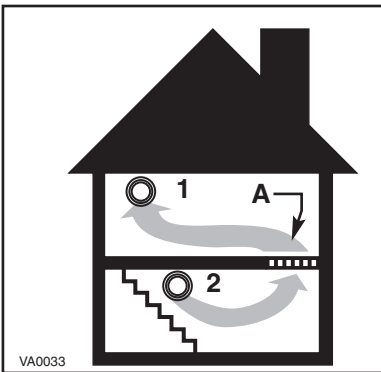

BUNGALOW

Basement stairwell (A): Closed.

One stale air exhaust register (1) in the highest lived-in level of the house and one fresh air distribution register (2) in the lowest lived-in level of the house. For the closed stairwell, use floor grilles (A).

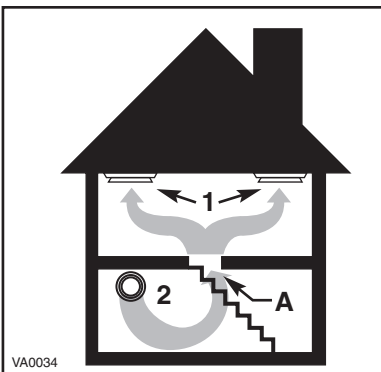

BUNGALOW

Basement stairwell (A): Open, central.

Two stale air exhaust registers (1) in the highest lived-in level of the house and one fresh air distribution register (2) in the lowest lived-in level of the house.

3. INSTALL THE UNIT (CONT'D)

3.5 INSTALLING 6" DUCTS AND REGISTERS (CONT'D)

3.5.3 SUGGESTED REGISTER LOCATIONS (CONT'D)

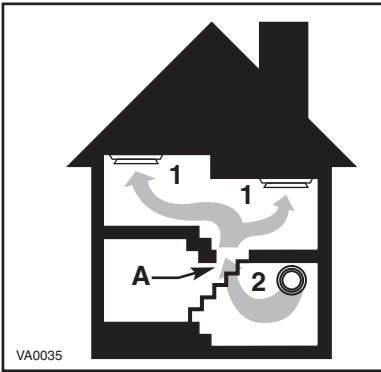

MULTI-LEVEL

Stairwell (A): Open, central.

Two stale air exhaust registers (1) in the upper lived-in levels of the house and one fresh air distribution register (2) in the lowest lived-in level of the house.

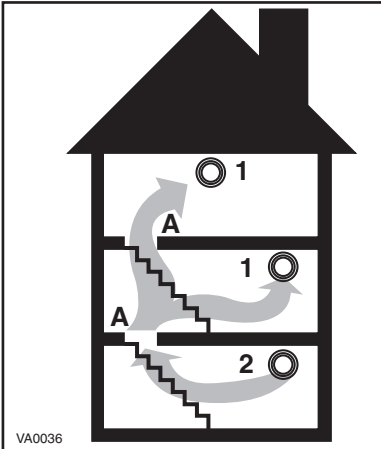

COTTAGE

Basement stairwell (A): Open.

Two stale air exhaust registers (1) in the upper lived-in levels of the house and one fresh air distribution register (2) in the lowest lived-in level of the house.

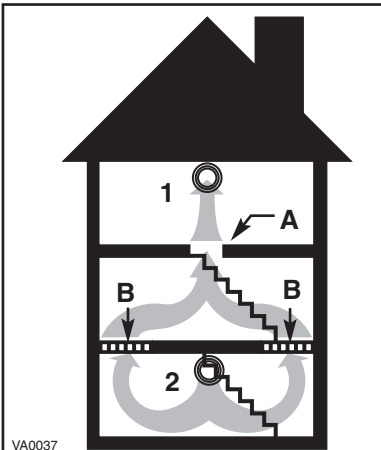

COTTAGE

Basement stairwell (A): One part open, some parts closed (B).

One stale air exhaust register (1) in the highest lived-in level of the house and one fresh air distribution register (2) in the lowest lived-in level of the house.

For the closed stairwell, use floor grilles (B).

3. INSTALL THE UNIT (CONT'D)

3.6 INSULATED FLEXIBLE DUCTS INSTALLATION

CAUTION

Make sure the vapor barrier on the insulated ducts does not tear during installation to avoid condensation within the ducts.

Use the following procedure for connecting the insulated flexible ducts to the unit ports (exhaust to outside and fresh air from outside).

- Pull back the insulation to expose the flexible duct.
- Connect the interior flexible duct to the port using a tie wrap.
- Carefully seal the connection with duct tape.
- Pull the insulation over the joint.
- Apply duct tape to the joint making an airtight seal. Avoid compressing the insulation when pulling the tape tightly around the joint; compressed insulation loses its R value and causes water dripping due to condensation on the exterior surface of the duct.

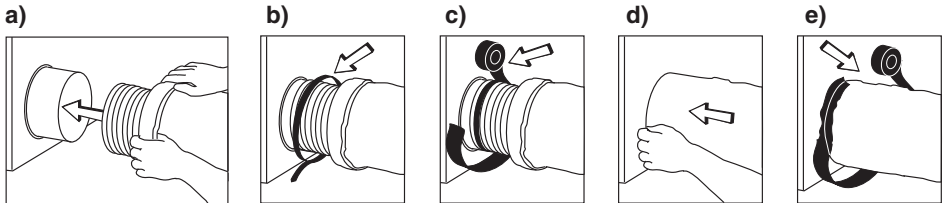

VJ0010

NOTE: In a retrofit installation, there may be only one insulated duct already installed for the unit ports.

- If the unit is installed in the attic, connect this insulated duct to the exhaust to outside port.
- If the unit is installed in the basement, connect this insulated duct to the fresh air intake port.

3.7 EXTERIOR OPENING(S) INSTALLATION

3.7.1 TANDEM TRANSITION WITH DUAL EXTERIOR HOOD

If the joists are perpendicular to the ducts, or if the connection to the exterior hood is in a limited area, the installation will need 2 exterior hoods (or soffit grilles). Go to Point 3.7.2 or 3.7.4 for more details.

3. INSTALL THE UNIT (CONT'D)

3.7 EXTERIOR OPENING(S) INSTALLATION (CONT'D)

3.7.1 TANDEM TRANSITION WITH DUAL EXTERIOR HOOD (CONT'D)

1. For each duct, pull back the insulation to expose the interior flexible duct.

CAUTION

Always connect the exhaust air to outside duct on top section of the Tandem transition.

2. Connect the interior flexible duct to the smaller part of the Tandem transition (5" oval) using a tie wrap.
3. Pull the insulation over the joint. Pull the vapor barrier over the insulation.
4. Apply duct tape gently to the joint in order to make an airtight seal. See figures below.

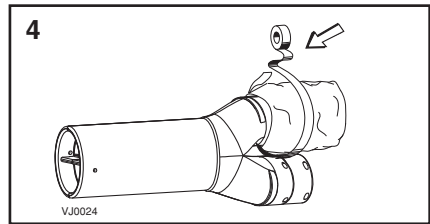
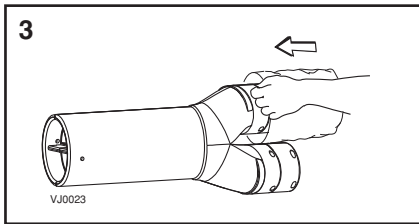
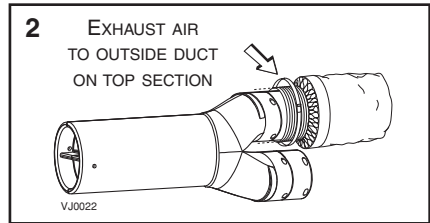
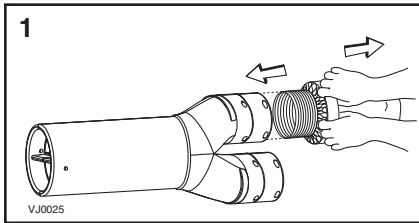

Dual exterior hood requires assembly. Using 2 no. 8 x 3/4" screws, assemble the top metal screen and the plastic grille to the dual exterior hood. Then, slide the bottom metal screen to the dual exterior hood. See illustration below.

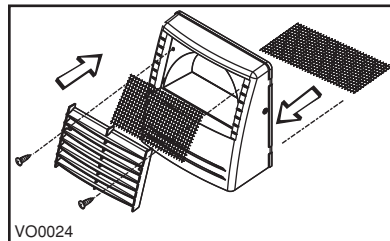

3. INSTALL THE UNIT (CONT'D)

3.7 EXTERIOR OPENING(S) INSTALLATION (CONT'D)

3.7.1 TANDEM TRANSITION WITH DUAL EXTERIOR HOOD (CONT'D)

The dual exterior hood must be installed at a minimum distance of 18 inches (457 mm) from the ground. See illustration beside.

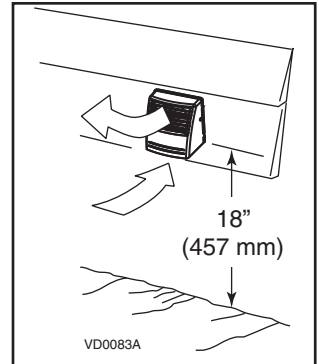

⚠ WARNING

Make sure this hood is at least 6 feet (1.8 m) away (or more, as per applicable building codes or standards) from sources of contamination such as:

- High efficiency furnace vent
- Any exhaust from a combustion source
- Gas meter exhaust, gas barbecue-grill
- Garbage bin

1. Using a jig saw, cut a 6" diameter hole in the exterior wall and insert the Tandem transition through this hole.

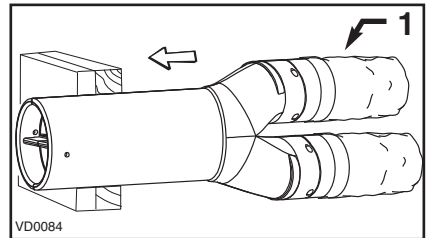

1) Exhaust air to outside duct

CAUTION

The Tandem transition must be inserted in such way that the exhaust air to outside duct will be located on the top.

3. INSTALL THE UNIT (CONT'D)

3.7 EXTERIOR OPENING(S) INSTALLATION (CONT'D)

3.7.1 TANDEM TRANSITION WITH DUAL EXTERIOR HOOD (CONT'D)

2. Join the end of the Tandem transition to the rear of the exterior backplate. Secure with 2 Xmas tree pins and seal properly with duct tape.

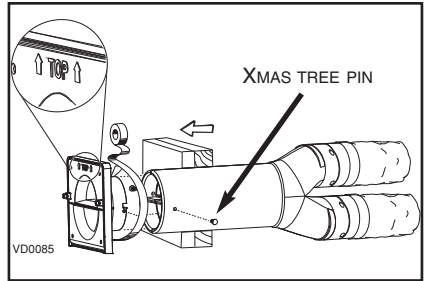

CAUTION

The exterior backplate must be installed with the word "TOP" pointing upward.

3. Lean the exterior backplate to the exterior wall. Using 4 no. 8 x 1½" screws, fix it to the wall. Seal the outline with caulking.

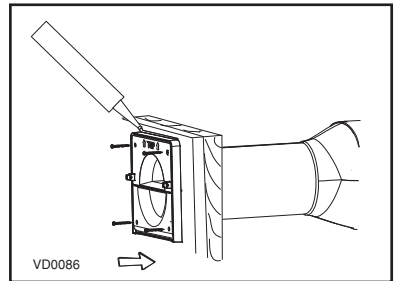

4. Snap the assembled exterior hood on its backplate and secure with 2 provided screws (no. 8 x 3/4" long).

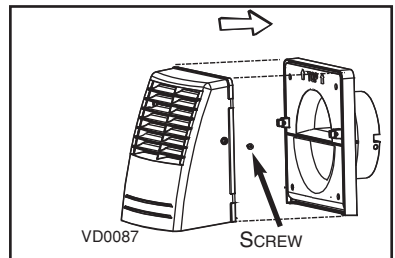

3. INSTALL THE UNIT (CONT'D)

3.7 EXTERIOR OPENING(S) INSTALLATION (CONT'D)

3.7.2 LOCATING 2 EXTERIOR HOODS

If this unit installation needs to have 2 exterior hoods, an additional exterior hood must be bought (sold separately, single exterior hood, part number 13940). Choose an appropriate location for installing the exterior hoods.

CAUTION

Due to its particular design, the dual exterior hood must be used only for exhaust hood when performing an installation using 2 exterior hoods. Use the single exterior hood for supply air.

⚠ WARNING

Make sure the single exterior hood is at least 6 feet (1.8 m) away (or more, as per applicable building codes or standards) from sources of contamination such as:

- High efficiency furnace vent
- Any exhaust from a combustion source
- Gas meter exhaust, gas barbecue-grill
- Garbage bin

- The dual exterior hood must be located at a minimum distance of 4 inches (102 mm) from the ground.
- The single exterior hood must be located at a minimum distance of 18 inches (457 mm) from the ground.
- There must be a minimum distance of 6 feet (1.8 m) between the hoods to avoid cross-contamination. See figure below.

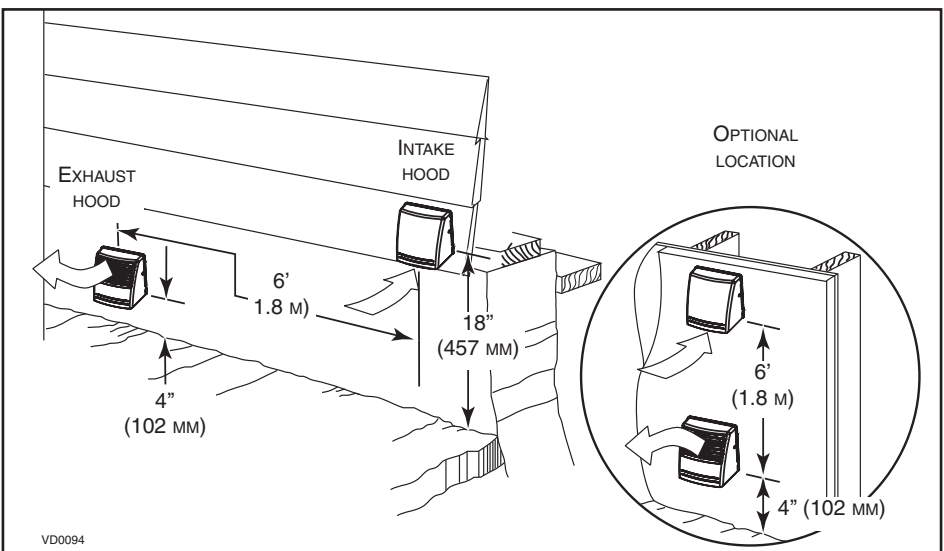

VD0094

3. INSTALL THE UNIT (CONT'D)

3.7 EXTERIOR OPENING(S) INSTALLATION (CONT'D)

3.7.3 CONNECTING INSULATED DUCTS TO 2 EXTERIOR HOODS

CAUTION

Make sure the insulated ductwork vapor barrier does not tear during installation.

1. For each exterior hood, using a jig saw, cut a 6" diameter hole in the exterior wall. Run each flexible duct through its respective hole in the wall.

CAUTION

The exterior backplate must be installed with the word "TOP" pointing upward.

2. For each exterior hood, pull back the insulation to expose the flexible duct and, using a tie wrap, attach it to the inner ring of the exterior backplate. Carefully seal with duct tape (A). Pull the insulation over the joint. Pull the vapor barrier over the insulation and over the outer ring of the exterior backplate. Gently apply duct tape to the joint making an airtight seal (B).

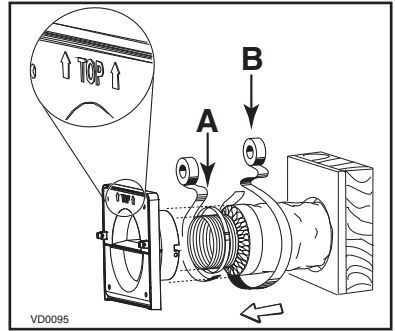

3. Attach the exterior backplate to the exterior wall. Using four provided screws, fix it to the wall. Seal the backplate with caulking, as shown beside.

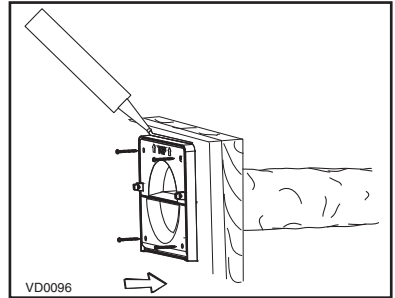

4. Snap each assembled exterior hood on its respective backplate location and secure each of them with their 2 provided screws.

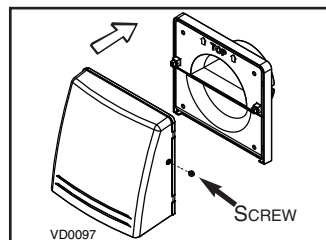
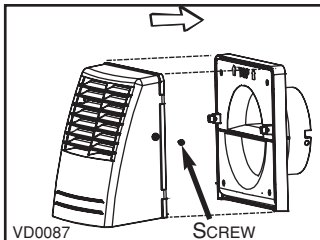

3. INSTALL THE UNIT (CONT'D)

3.7 EXTERIOR OPENING(S) INSTALLATION (CONT'D)

3.7.4 LOCATING 2 SOFFIT GRILLES

If this unit is installed in the attic, use the installation kit no. EA20130 (not available in the U.S.A.). Choose an appropriate location for installing the soffit grilles (included in the installation kit no. EA20130).

⚠ WARNING

Make sure the air intake grille is at least 6 feet (1.8 m) away (or more, as per applicable building codes or standards) from sources of contamination such as:

- High efficiency furnace vent
- Any exhaust from a combustion source
- Gas meter exhaust, gas barbecue-grill
- Garbage bin

- Do not locate where prevailing winds blow the stale air towards the fresh air vent.
- There must be a minimum distance of 6 feet (1.8 m) between the grilles to avoid cross-contamination. See illustration beside.

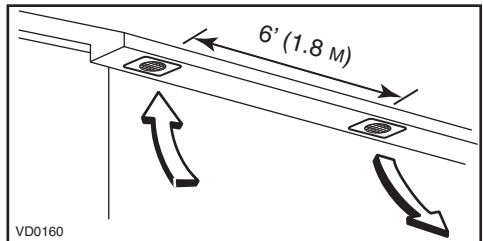

3.7.5 CONNECTING INSULATED DUCTS TO 2 SOFFIT GRILLES

CAUTION

Make sure the insulated ductwork vapor barrier does not tear during installation.

1. For each exterior hole, using a jig saw, cut a 4¼" diameter hole in the soffit. Pull back the insulation to expose the flexible duct. Run each flexible duct through its respective hole.
2. Using provided screws, attach the flexible duct to the ring of the soffit grille. Carefully seal with duct tape. Assemble the soffit grilles to the soffit.

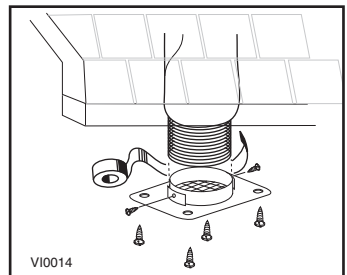

4. CONTROL

4.1 INSTALLATION OF THE CONTROL

⚠ WARNING

Always disconnect the unit before making any connections. Failure in disconnecting power could result in electrical shock or damage of the control or electronic module of the unit.

CAUTION

Never install more than one optional control per unit.

1. Determine the more convenient location for the control.

2. Remove the cover plate control (1). If you prefer to mount the control on an approved outlet box or an approved mounting bracket (not included), discard the backplate (2).

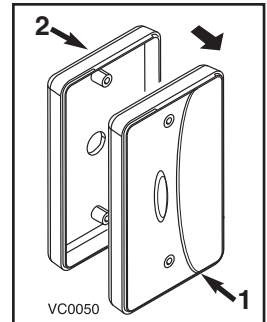

⚠ WARNING

To avoid risk of electrical shocks, never install another wire in the same electrical box than the one for the control.

3. Take one end of the cable and pass it through the control backplate (or outlet box or mounting bracket).
4. Splice back this end of the cable to access the 4 wires. Remove the insulated sleeve of each wire ends. Make a loop with each bare end wire to hook them to their corresponding screw. Connect YELLOW wire to "Y" screw, RED wire to "R" screw, GREEN to "G" screw and BLACK to "B" screw. See illustration below.

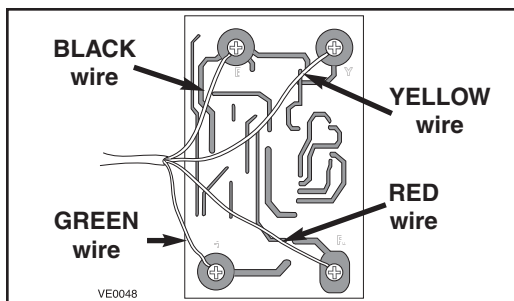

⚠ WARNING

Make sure that the wires don't short circuit between themselves or by touching any other components on the control.

4. CONTROL (CONT'D)

4.1 INSTALLATION OF THE CONTROL (CONT'D)

5. Pass the other end of the cable through the wall. Reinstall the cover plate. Using wall anchors (not included) and provided screws, mount the control on the wall. See illustrations below.

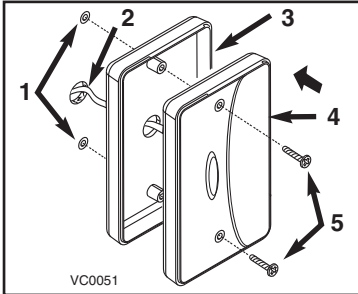

- 1) WALL ANCHORS
2) CONTROL CABLE
3) CONTROL BACKPLATE
4) CONTROL
5) SCREWS

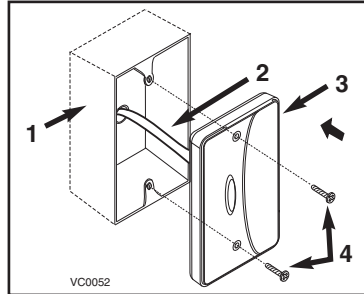

- 1) OUTLET BOX
2) CONTROL CABLE
3) CONTROL
4) SCREWS

6. Route the cable to the unit.

CAUTION

Keep control low voltage wiring at least 1 foot (305 mm) away from motors, lightning ballast, light dimming circuit and power distribution panel. Do not route control wiring along with house power wiring. Avoid poor wiring connections. Failure to follow these practices can introduce electrical interference, which can cause erratic control operations.

7. Remove the electrical box cover on the side of the unit.
8. Slide the sleeve (included) over the cable control and pass the cable through the grommet.

CAUTION

The sleeve must stay in the grommet. See figure below.

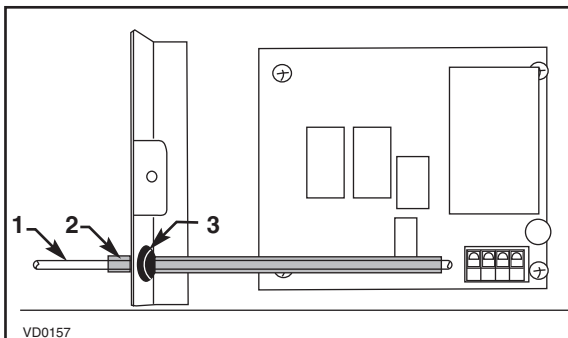

- 1) CABLE CONTROL
2) SLEEVE
3) GROMMET

4. CONTROL

4.1 INSTALLATION OF THE CONTROL (CONT'D)

9. Splice back the end of the cable to access the 4 wires. Remove the insulated sleeve of each wire ends. Connect each wires in their corresponding terminal (YELLOW in "Y", RED in "R", GREEN in "G" and BLACK in "B").
10. Reinstall the electric box cover and plug the unit.

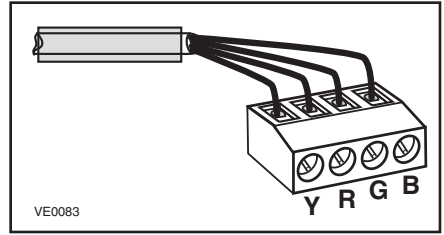

4.2 OPERATING THE CONTROL

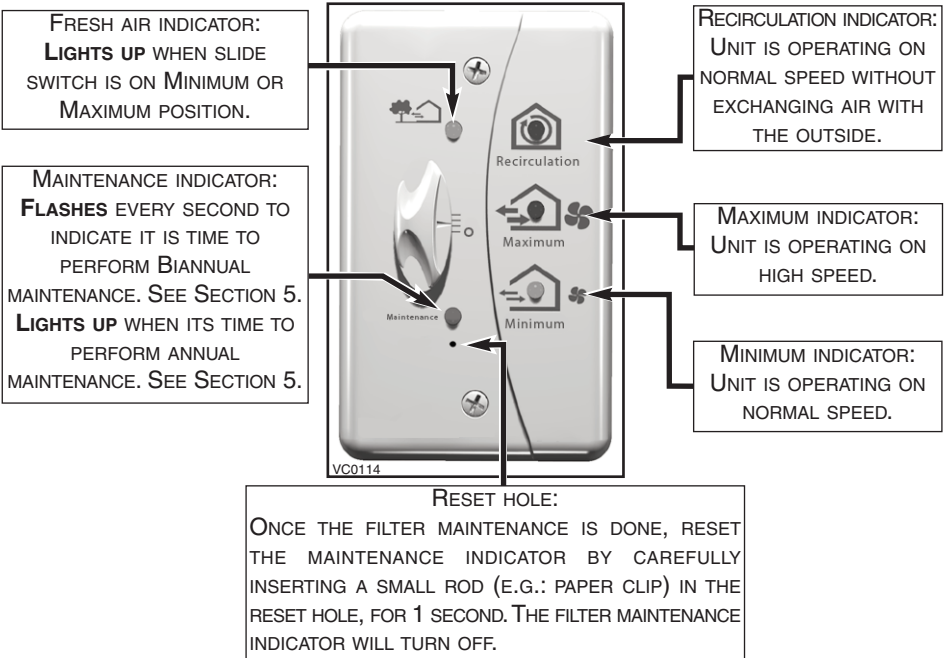

4. CONTROL (CONT'D)

4.2 OPERATING THE CONTROL (CONT'D)

- **“O”:** To stop the unit, slide the button on this position.
- **MINIMUM:** For a day-to-day usage, slide the button on this position. The unit then will operate on normal speed.
- **MAXIMUM:** For a high speed operation, slide the button on this position. Generally used when extreme conditions occur, e.g.: parties, smokers, etc.
- **RECIRCULATION:** For a normal speed operation, without exchanging air with the outside, slide the button on this position. This mode is recommended in high humidity days (rain, heat wave). Also, use it when the outside temperature is extremely cold and/or the inside air is too dry. It can be used also to recirculate the heat coming from a wood stove throughout the house, or the fresh air from a cooling system.

5. MAINTENANCE

⚠ WARNING

Risk of electrical shocks. Before performing any maintenance or servicing, always disconnect the unit from its power source. It is recommended to wear safety glasses and gloves when performing maintenance or servicing.

5.1 BIENNIAL MAINTENANCE

1. Disconnect the power supply.

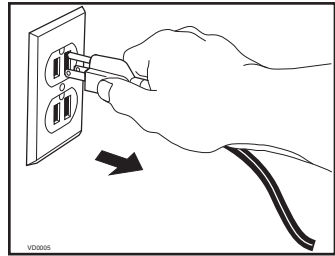

2. Clean **filter**

- Remove filter.
- Vacuum to remove most of the dust.
- Wash with a mixture of warm water and mild soap. You may add bleach if you wish to disinfect (one tablespoon per gallon). Rinse thoroughly. Shake filter to remove excess water and let dry.

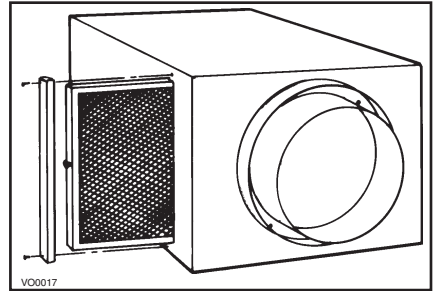

NOTE: Washing the filter in the top tray of the dishwasher is possible, but the aluminum frame might tarnish.

3. Plug back the unit.

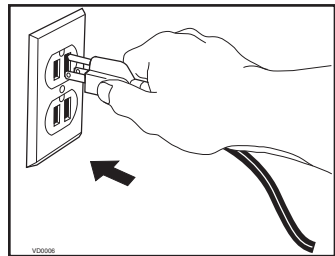

4. Reset the maintenance indicator by inserting a small rod (e.g.: paper clip end) into the optional control reset hole. Press lightly until the Maintenance indicator light turns off.

5. MAINTENANCE (CONT'D)

5.2 ANNUAL MAINTENANCE

1. Disconnect the power supply.

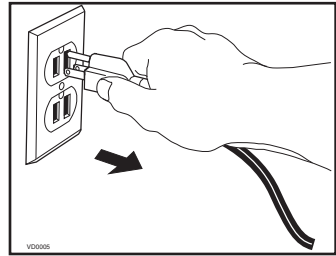

2. Clean **filter**
 - Remove filter.
 - Vacuum to remove most of the dust.
 - Wash with a mixture of warm water and mild soap. You may add bleach if you wish to disinfect (one tablespoon per gallon). Rinse thoroughly. Shake filter to remove excess water and let dry.

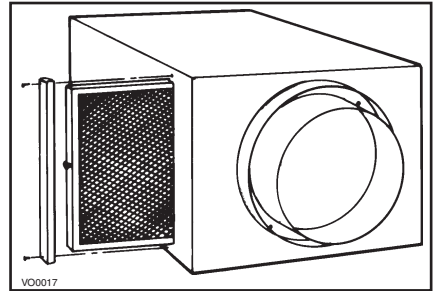

NOTE: Washing the filter in the top tray of the dishwasher is possible, but the aluminum frame might tarnish.

CAUTION

Even a partial blocking of this air vent could cause the unit to malfunction.

3. Check the exterior **air intake hood**:
 - Make sure there are no leaves, twigs, ice or snow that could be drawn into the vent.
 - Clean if necessary.

4. Plug back the unit.

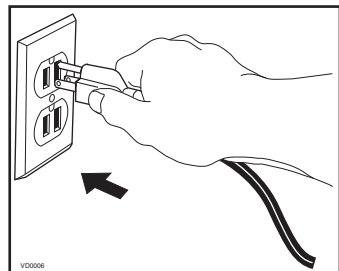

5. Reset the maintenance indicator by inserting a small rod (e.g.: paper clip end) into the optional control reset hole. Press lightly until the Maintenance indicator light turns off.

5. MAINTENANCE (CONT'D)

5.3 MASTER RESET

Use the master reset only if you perform the annual maintenance before the annual maintenance indicator is on. By inserting a small rod (e.g.: paper clip end) during 5 seconds and more into the control reset hole, a master reset will be done and both biannual and annual maintenance filter are reset.

If the control is on "O" position, fresh air light indicator will flash for 1 second.

If the control is on Minimum or Maximum position, the unit motor and the fresh air light indicator will turn off for 3 seconds.

If the control is on Recirculation position, the unit motor will turn off during 3 seconds.

6. TROUBLESHOOTING

PROBLEMS	SOLUTIONS
1. Unit does not start on Minimum or Maximum position.	<ul style="list-style-type: none">• Check breaker or fuse in main distribution panel.• Check if there is 120V at the electrical outlet.
2. Unit does not run on Minimum, but runs on Maximum.	<ul style="list-style-type: none">• Check control wiring and control connections.
3. Unit does not work.	<ul style="list-style-type: none">• The fuse may be blown. Unplug the unit. Unscrew the electrical enclosure. Check if the fuse is blown on the electronic control board (the strand is broken). If it is blown, replace the fuse with the exact same type.
4. Unit is not operating as per the selected mode.	<ul style="list-style-type: none">• Check control wiring.
5. Control indicators do not work properly or not at all.	<ul style="list-style-type: none">• Check control wiring.
6. Air is too dry.	<ul style="list-style-type: none">• Avoid operating the unit on Maximum mode.• Use the Recirculation mode.
7. Persistent condensation.	<ul style="list-style-type: none">• Turn on the central heating system.• Store the firewood outside the house.• Do not completely close curtains, blinds, etc.

If the problem is still not solved, call your installer or the nearest approved Service Center.

You can also reach the Customer Service Department at the following telephone numbers:

Exclusively for model AE60: 1-800-637-1453.

Exclusively for model EA1500: 1-800-567-3855.

Exclusively for model HV 1.5: 1-866-737-7770.