

INSTALLATION GUIDE FOR AVS HRV EKO 1.5, AVS CONSTRUCTO 1.5V, HRV 90H-V ECM AND 90H-V UNITS



THIS UNIT HAS A SPECIAL START-UP
PROCEDURE, REFER TO PAGE 12.



VB0119

THIS UNIT HAS A SPECIAL START-UP
PROCEDURE, REFER TO PAGE 12.



⚠ RESIDENTIAL USE ONLY ⚠

READ AND SAVE THESE INSTRUCTIONS



These products earned the ENERGY STAR® by meeting strict energy efficiency guidelines set by Natural Resources Canada and the US EPA. They meet ENERGY STAR requirements only when used in Canada.

ABOUT THIS MANUAL

Because of the large amount of models covered in this publication, the illustrations are typical ones. Some details of your unit may be slightly different than the ones shown.

Please take note that this manual uses the following symbols to emphasize particular information:

WARNING

Identifies an instruction which, if not followed, might cause serious personal injuries including possibility of death.

CAUTION

Denotes an instruction which, if not followed, may severely damage the unit and/or its components.

NOTE: Indicates supplementary information needed to fully complete an instruction.

We welcome any suggestions you may have concerning this manual and/or the unit, and we would appreciate hearing your comments on ways to better serve you. Please contact us by phone at 1-800-567-3855.

ABOUT THESE UNITS

LIMITATION

For residential (domestic) installation only. This unit must be installed in accordance with all national and local regulations, building codes and safety codes.

WARNING

TO REDUCE THE RISK OF FIRE, ELECTRIC SHOCK, OR INJURY TO PERSON(S) OBSERVE THE FOLLOWING:

1. Use this unit only in the manner intended by the manufacturer. If you have questions, contact the manufacturer at the address or telephone number listed in the warranty.
2. Before servicing or cleaning the unit, disconnect power cord from electrical outlet.
3. This unit is not designed to provide combustion and/or dilution air for fuel-burning appliances.
4. When cutting or drilling into wall or ceiling, do not damage electrical wiring and other hidden utilities.
5. Do not use the units with any solid-state speed control device other than the corresponding ones listed below:

UNIT	MAIN CONTROL	AUXILIARY CONTROL
AVS HRV EKO 1.5	ALTITUDE	20/40/60-MINUTE PUSH-BUTTON TIMER AND 60-MINUTE CRANK TIMER
HRV 90H-V ECM	PLATINUM	20/40/60-MINUTE PUSH-BUTTON TIMER AND 60-MINUTE CRANK TIMER
AVS CONSTRUCTO 1.5V	LITE-TOUCH CONSTRUCTO OR CONSTRUCTO	20-MINUTE LIGHTED PUSH-BUTTON TIMER, DEHUMIDISTAT AND 60-MINUTE CRANK TIMER
90H-V	LITE-TOUCH OR BRONZE	20-MINUTE LIGHTED PUSH-BUTTON TIMER, HUMIDITY CONTROL AND 60-MINUTE CRANK TIMER

6. This unit must be grounded. The power supply cord has a 3-prong grounding plug for your personal safety. It must be plugged into a mating 3-prong grounding receptacle, grounded in accordance with the national electrical code and local codes and ordinances. Do not remove the ground prong. Do not use an extension cord.
7. Do not install in a cooking area or connect directly to any appliances.
8. Do not use to exhaust hazardous or explosive materials and vapors.
9. When performing installation, servicing or cleaning these units, it is recommended to wear safety glasses and gloves.
10. Due to the weight of the unit, two installers are recommended to perform installation.
11. When applicable local regulations comprise more restrictive installation and/or certification requirements, the aforementioned requirements prevail on those of this document and the installer agrees to conform to these at his own expenses.

CAUTION

1. To avoid premature clogged filters, turn OFF the unit during construction or renovation.
2. Please read specification label on product for further information and requirements.
3. Be sure to duct air outside – Do not intake/exhaust air into spaces within walls or ceiling or into attics, crawl spaces, or garage.
4. Intended for residential installation only in accordance with the requirements of NFPA 90B (for a unit installed in USA) or Part 9 of the National Building Code of Canada (for a unit installed in Canada).
5. Do not run any air ducts directly above or closer than 2 ft (0.61 m) to any furnace or its supply plenum, boiler, or other heat producing appliance. If a duct has to be connected to the furnace return plenum, it must be connected not closer than 9' 10" (3 m) from this plenum connection to the furnace.
6. The ductwork is intended to be installed in compliance with all applicable codes.
7. When leaving the house for a long period of time (more than two weeks), a responsible person should regularly check if the unit operates adequately.
8. If the ductwork passes through an unconditioned space (e.g.: attic), the unit must operate continuously except when performing maintenance and/or repair. Also, the ambient temperature of the house should never drop below 18°C (65°F).

TABLE OF CONTENTS

1. TECHNICAL DATA	4
1.1 AIR DISTRIBUTION	4
1.2 DEFROST CYCLES	4
1.3 DIMENSION	4
2 TYPICAL INSTALLATIONS	5
2.1 FULLY DUCTED SYSTEM	5
2.2 CENTRAL DRAW POINT	5
2.3 SIMPLIFIED INSTALLATION	5
3 INSTALLATION	6-11
3.1 INSPECT THE CONTENT OF THE BOX	6
3.2 UNIT DOOR(S)	6
3.3 LOCATING THE UNIT	6
3.4 PLANNING OF THE DUCTWORK	7
3.5 CALCULATING DUCT SIZE	7
3.6 INSTALLING THE DUCTWORK AND REGISTERS	8-9
3.7 CONNECTING THE DUCTS TO THE UNIT	10
3.8 INSTALLING TWO EXTERIOR HOODS	11
3.9 CONNECTING THE DRAIN	11
4. CONTROLS	12-14
4.1 INTEGRATED CONTROL	12
4.2 UNITS BOOTING SEQUENCE	12
4.3 SPEED AND DEFROST SETTINGS FOR AVS HRV EKO 1.5 AND HRV 90H-V ECM UNITS	13
4.4 SETTING EXTENDED DEFROST FOR AVS CONSTRUCTO 1.5V AND 90H-V UNITS	13
4.5 ELECTRICAL CONNECTION TO MAIN CONTROLS	14
4.6 ELECTRICAL CONNECTION TO OPTIONAL AUXILIARY CONTROLS	15
5. ELECTRICAL CONNECTION TO THE FURNACE	16
6. WIRING DIAGRAMS	17-18
7. BALANCING THE UNIT	19
7.1 WHAT YOU NEED TO BALANCE THE UNIT	19
7.2 PRELIMINARY STAGES TO BALANCE THE UNIT	19
7.3 BALANCING PROCEDURE	19
8. SERVICE PARTS	20
9. TROUBLESHOOTING	21-22

1. TECHNICAL DATA

1.1 AIR DISTRIBUTION

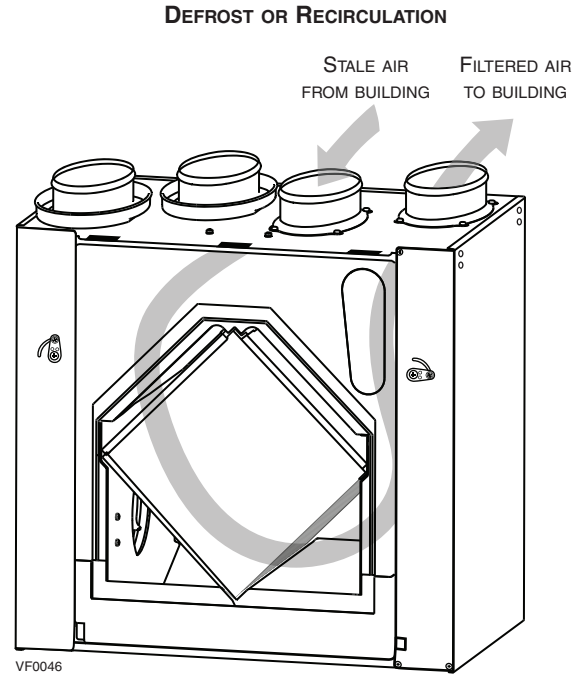
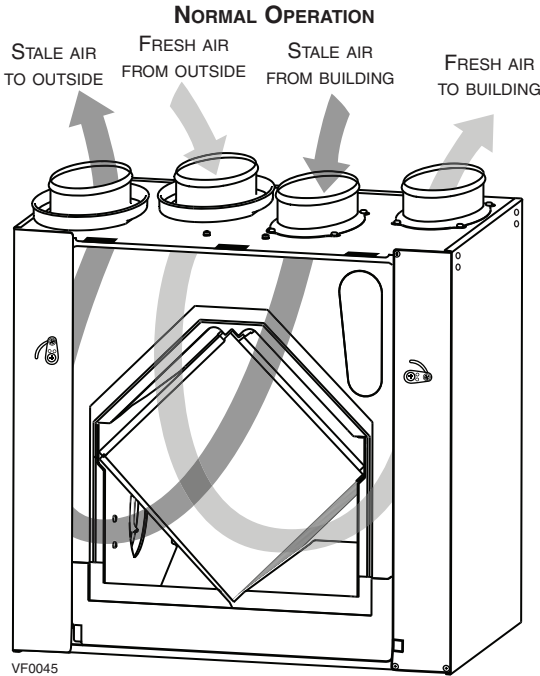

1.2 DEFROST CYCLES

				AVS HRV EKO 1.5 AND HRV 90H-V ECM UNITS		AVS CONSTRUCTO 1.5V AND 90H-V UNITS	
OUTSIDE TEMPERATURE		DEFROST CYCLES (MINUTES)		EXTENDED DEFROST CYCLES (MIN.)		EXTENDED DEFROST CYCLES (MIN.)	
CELSIUS (°C)	FAHRENHEIT (°F)	DEFROSTING	OPERATION BETWEEN EACH DEFROST CYCLE	DEFROSTING	OPERATION BETWEEN EACH DEFROST CYCLE	DEFROSTING	OPERATION BETWEEN EACH DEFROST CYCLE
-5	23	7	25	10	20	9	23
-15	-5	7	25	10	20	9	23
-27	-17	10	22	10	15	10	22

In a cold region, (outside temperature -27°C [-17°F] and lower), it may be necessary to setup EXTENDED DEFROST. See Section 4.3 or 4.4, according to the unit model.

1.3 DIMENSIONS

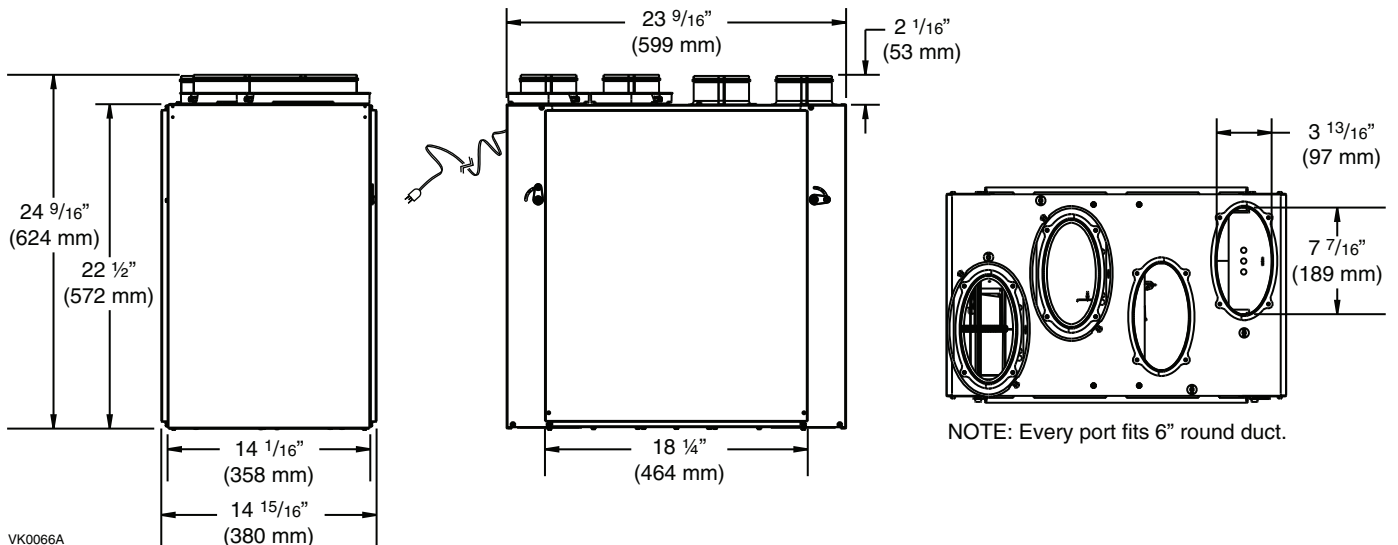

2. TYPICAL INSTALLATIONS

Use the following illustrations as guidelines to help you decide on how the unit will be installed.

All the units should be hung from the joists.

If required, bathroom fans and a range hood may be used to exhaust stale air. Also, for homes with more than one level, we recommend one exhaust register at the highest level.

There are 3 installation methods: Fully ducted, Central Draw Point and Simplified Installation.

NOTE: An electrical outlet has to be available within 3 feet of the unit.

2.1 FULLY DUCTED SYSTEM (PRIMARYLY FOR HOMES WITH RADIANT HOT WATER OR ELECTRIC BASEBOARD HEATING)

Stale air coming from the registers located at the highest level of the house is exhausted to the outside. Fresh air from outside is filtered and supplied by the register located in the lowest liveable level.

Homes with more than one level require at least one exhaust register at the highest level.

See figure at right.

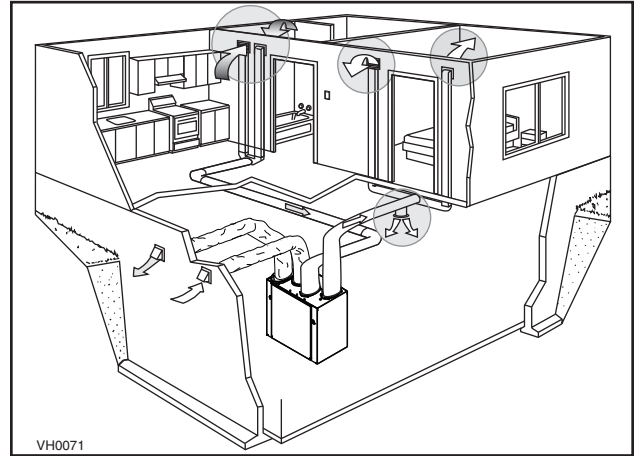

2.2 CENTRAL DRAW POINT (CONNECTION TO A FORCED AIR SYSTEM)

Stale air coming from the registers located at the highest level of the house is exhausted to the outside. Fresh air from outside is filtered and supplied to the return (plenum) or the supply duct of the forced air unit. See figure at right.

For this type of installation, it is not essential that the forced air system blower runs when the unit is in operation, but we recommend it.

NOTE: Home with multiple forced air systems should have one unit on each system.

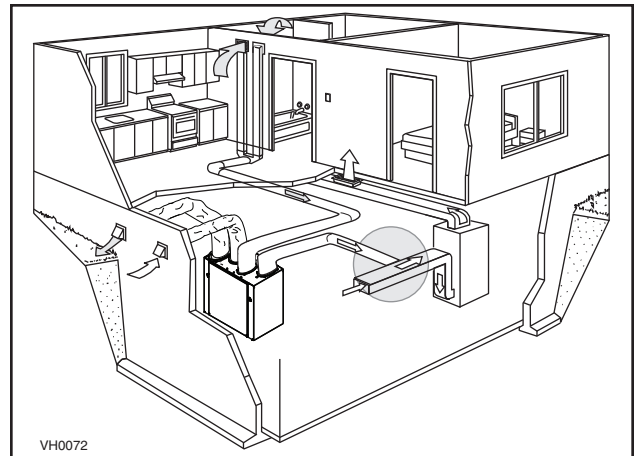

2.3 SIMPLIFIED INSTALLATION (CONNECTION TO A FORCED AIR SYSTEM)

Stale air is exhausted to the outside. Fresh air from outside is filtered and supplied to the return (plenum) or the supply duct of the forced air unit. See figure at right.

To avoid cross-contamination and achieve the highest efficiencies, the forced air system blower must always be ON.

NOTE: Home with multiple forced air systems should have one unit on each system.

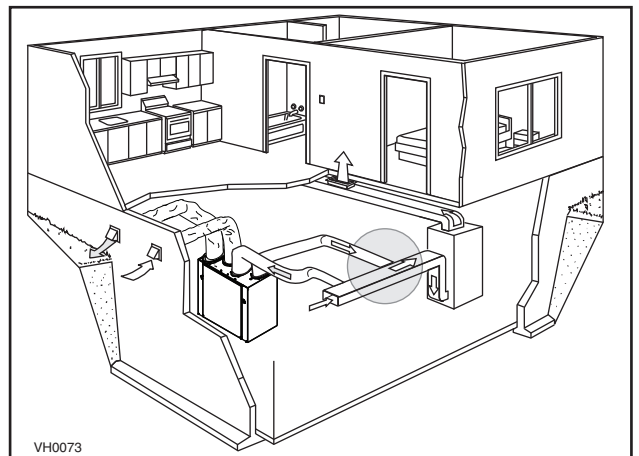

3. INSTALLATION

3.1 INSPECT THE CONTENT OF THE BOX

Inspect the exterior of the unit for shipping damage. Ensure that there is no damage to the door, ports, power cord, etc.

3.2 UNIT DOOR(S)

The AVS HRV EKO 1.5 and the HRV 90H-V ECM units have one front door and one back door while the AVS Constructo 1.5V and the 90H-V units only have one door. For these last models, the unit door can be relocated on the back of the unit. This can be helpful to optimize duct configuration while keeping access for unit maintenance. To change door location, follow these steps:

- A. Remove both door lower mechanical screws no. 8-32 x 1" (1) and set aside.
- B. Open (2) and lift out the door (3).

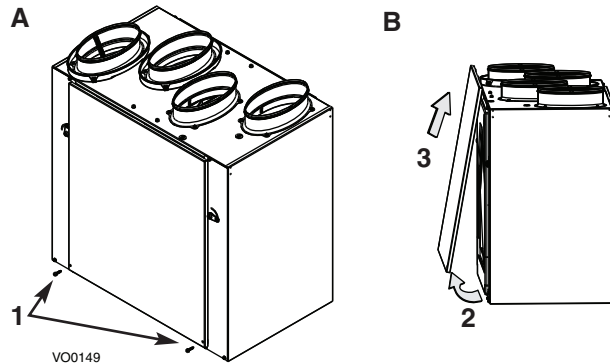

To remove unit back panel, repeat steps **A** and **B**, but instead of removing 2 mechanical screws, there are 4 metal screws to be removed. Hang the door to the back of the unit and secure it by tightening its both lower mechanical screws. Hang back panel to the front of the unit and secure it by tightening its four metal screws.

3.3 LOCATING THE UNIT

Choose an appropriate location for the unit.

- Within an area of the house where the ambient temperature is between 10°C (50°F) and 50°C (122°F) (basement, furnace room, closet, etc.).
- Away from living areas (dining room, living room, bedroom), if possible.
- So as to provide easy access to the interior of the unit, for maintenance.
- Close to an exterior wall, so as to limit the length of the insulated flexible duct to and from the unit.
- Away from hot chimneys and other fire hazards.
- Allow for a power source (standard 3-prong grounding outlet).
- Close to a drain. If no drain is close by, use a pail to collect run-off.

Hang the unit with the four chains and springs provided.
See illustration beside.

CAUTION

Make sure the unit is level.

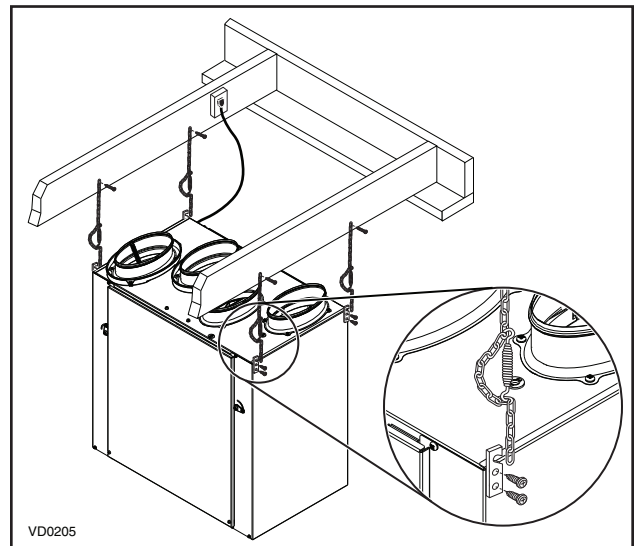

3. INSTALLATION (CONT'D)

3.4 PLANNING OF THE DUCTWORK

- Keep it simple. Plan for a minimum of bends and joints.
- Keep the length of insulated ducts to a minimum.
- Do not ventilate crawl spaces or cold rooms. Do not attempt to recover the exhaust air from a dryer or a range hood. This would cause clogging of the filters and recovery module.
- If the house has two floors or more, be sure to plan for at least one exhaust register on the highest lived-in level.

3.5 CALCULATING DUCT SIZE

Use the table below to ensure that the ducts you intend to install will be carrying air flows at or under the recommended values. Avoid installing ducts that will have to carry air flows near the maximum values and never install a duct if its air flow exceeds the maximum value.

DUCT DIAMETER	RECOMMENDED AIR FLOW	MAXIMUM AIR FLOW
4" Ø (102 MM)	40 CFM (19 L/S OR 68 M ³ /H)	60 CFM (28 L/S OR 102 M ³ /H)
5" Ø (127 MM)	75 CFM (35 L/S OR 127 M ³ /H)	110 CFM (52 L/S OR 187 M ³ /H)
6" Ø (152 MM)	120 CFM (57 L/S OR 204 M ³ /H)	180 CFM (85 L/S OR 306 M ³ /H)

NOTE: Examples 3.5.1 and 3.5.2 use imperial units. The same calculation applies to metric units.

3.5.1 Example of calculation

Problem: My installation requires two exhaust registers (one for the kitchen, and the other for the bathroom). I will connect these registers to a main duct which will connect to the unit (high speed performance value of 140 cfm). What size of duct should I use for the main exhaust duct and for both end branches leading to the registers? (See illustration beside.)

Solution: Simplified method. (For a more detailed method of calculating duct size, refer to the ASHRAE or HRAI HANDBOOK.)

Main duct: Table indicates for a 6" Ø duct: recommended air flow: 120 cfm, maximum air flow: 180 cfm. The 140 cfm high speed air flow is close enough to the recommended value (120) and far away enough from the maximum value (180). Therefore, a 6" Ø duct or larger is an appropriate choice for the main exhaust duct.

End branches: Each end branch will have to transport a 70 cfm air flow (140 divided by 2). Table indicates for a 5" Ø duct: recommended air flow: 75 cfm; maximum air flow: 110 cfm. The high speed air flow of 70 cfm is close enough to the recommended value (75) and far away enough from the maximum value (110). Therefore, a 5" Ø duct or larger is an appropriate choice for both end branches.

NOTE: A 4" Ø duct would have been too small because the maximum acceptable value for a 4" Ø duct is 60 cfm.

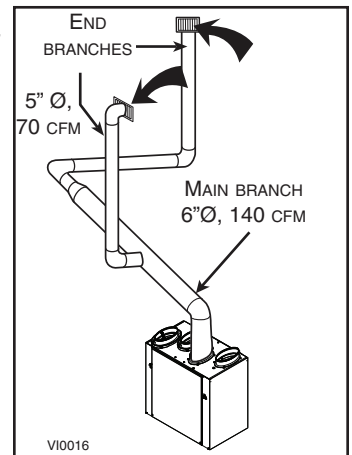

3.5.2 Example of a design for a fully ducted system with a unit having a high speed performance of 160 cfm.

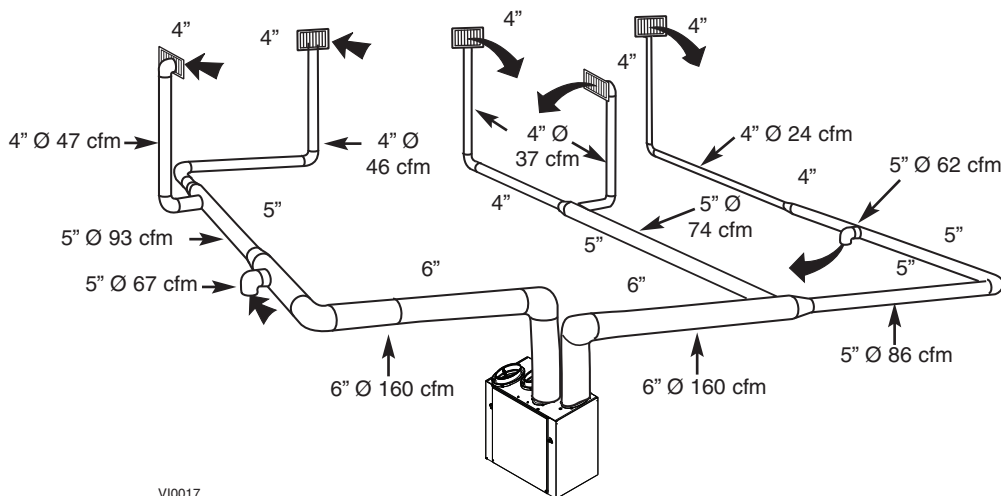

3. INSTALLATION (CONT'D)

3.6 INSTALLING THE DUCTWORK AND REGISTERS

3.6.1 FULLY DUCTED SYSTEM (AS ILLUSTRATED IN SECTION 2.1)

⚠ WARNING

Never install a stale air exhaust register in a closed room where a combustion device operates, such as a gas furnace, a gas water heater or a fireplace.

Stale air exhaust ductwork

- Install the stale air exhaust registers where the contaminants are produced: kitchen, living room, etc. Position the registers as far from the stairway as possible and in such a way that the air circulates in all the lived-in spaces in the house.
- If a register is installed in the kitchen, it must be located at least 4 feet (1.2 m) from the range.
- Install the registers 6 to 12 inches (152 to 305 mm) from the ceiling on an interior wall OR install them in the ceiling.
- If possible, measure the velocity of the air flowing through the registers. If the velocity is higher than 400 ft/min (122 m/min), then the register type is too small. Replace with a larger one.

Fresh air distribution ductwork

- Install the fresh air distribution registers in bedrooms, dining rooms, living room and basement.
- Keep in mind that the fresh air registers must be located as far as possible from the stale air registers.
- Install the registers either in the ceiling or high on the walls with air flow directed towards the ceiling. (The cooler air will then cross the upper part of the room and mix with room air, before descending to occupant's level.)
- If a register must be floor installed, direct the airflow up the wall.

3.6.2 CENTRAL DRAW POINT SYSTEM (AS ILLUSTRATED IN SECTION 2.2)

Stale air exhaust ductwork

Same as for Fully Ducted System, described on point 3.6.1)

⚠ WARNING

When performing duct connections, always use approved tools and materials. Respect all corresponding laws and safety regulations. Please refer to your local building code.

CAUTION

When performing duct connections to the furnace supply duct, this duct must be sized to support the additional airflow produced by the HRV. Also, the use of metal duct is highly recommended.

Fresh air distribution ductwork

There are 2 methods for connecting the unit to the furnace/air handler:

Method 1: Supply side connection

- Cut an opening into the furnace supply duct at least 18 inches (0.5 m) from the furnace/air handler.
- Connect this opening to the **Fresh air distribution** port of the HRV (use **metal duct**, see figure beside).
- Make sure the HRV duct form an elbow inside the furnace/air handler ductwork.
- If desired, interlock (synchronize) the furnace/air handler blower operation (see Section 5 ELECTRICAL CONNECTION TO FURNACE).

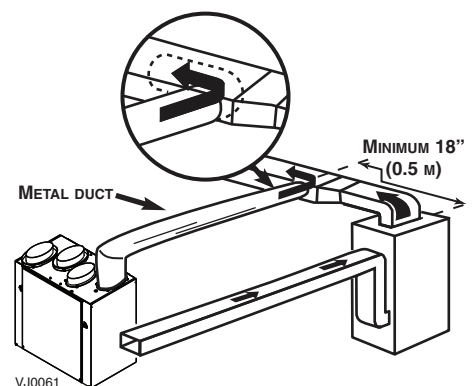

Method 2: Return side connection

- Cut an opening into the furnace return duct not less than 10 feet (3.1 m) from the furnace/air handler (A+B).
- Connect this opening to the **Fresh air distribution** port of the HRV (see figure beside).

NOTE: For Method 2, it is not essential that the furnace/air handler runs when the unit is operation, but we recommend it. If desired, interlock (synchronize) the furnace/air handler blower operation (see Section 5 ELECTRICAL CONNECTION TO FURNACE).

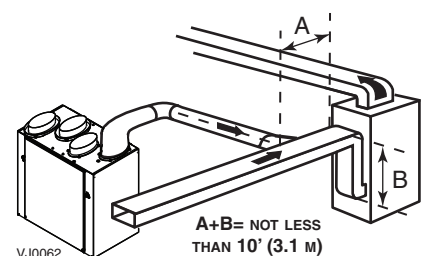

3. INSTALLATION (CONT'D)

3.6 INSTALLING THE DUCTWORK AND REGISTERS (CONT'D)

3.6.3 SIMPLIFIED INSTALLATION (AS ILLUSTRATED IN SECTION 2.3)

⚠ WARNING

When performing duct connections, always use approved tools and materials. Respect all corresponding laws and/or safety regulations. Please refer to your local building code.

CAUTION

When performing duct connections to the furnace supply duct (Method 1), this duct must be sized to support the additional airflow produced by the HRV. Also, the use of metal duct is highly recommended. For a Return-Return installation, the furnace blower must be in operation when the HRV is in operation.

There are 2 methods for connecting the unit to the furnace/air handler:

Method 1: Supply-return connection

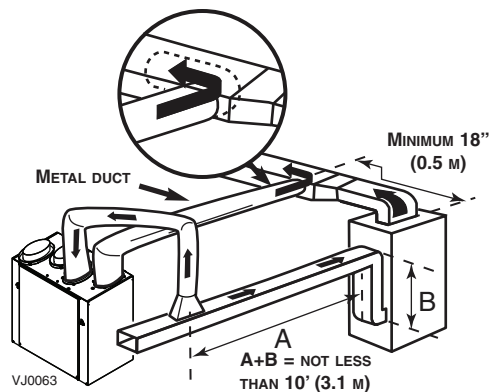

Method 2: Return-return

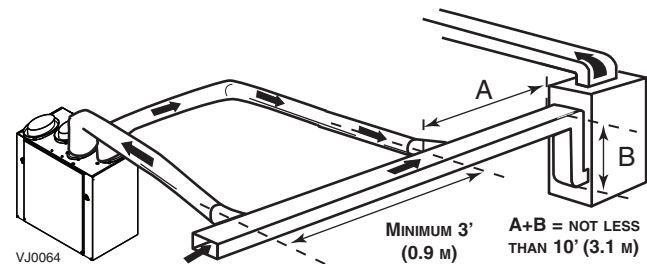

Stale air intake

- Cut an opening into the furnace/air handler return duct not less than 10 feet (3.1 m) from the furnace/air handler (A+B).
- Connect this opening to the **Exhaust air from building** port of the HRV.

Fresh air distribution

- Same instructions as for Method 1 or Method 2, Section 3.6.2.

For Method 2 (Return-return), make sure there is a distance of at least 3 feet (0.9 m) between the 2 connections to the furnace/air handler.

CAUTION

If using Method 2, make sure the furnace/air handler blower operation is synchronized with the unit operation! See Section 5.

NOTE: For Method 1, it is not essential to synchronize the furnace blower operation with the unit operation, but we recommend it.

3. INSTALLATION (CONT'D)

3.7 CONNECTING THE DUCTS TO THE UNIT

Insulated flexible ducts

Use the following procedure to connect the insulated flexible ducts to the ports of the unit (**Exhaust air to outside** and **Fresh air from outside** ports).

1. Pull back the insulation to expose the flexible duct.
2. Attach the flexible duct to the port using tie wrap.
3. Pull the insulation over the joint and tuck in between the inner and outer rings of the double collar.
4. Pull down the vapor barrier (shaded part in illustrations below) over the outer ring to cover it completely. Fasten in place the vapor barrier using the port strap (included in unit parts bag). To do so, insert one collar pin through vapor barrier and first strap hole, then insert the other collar pin through vapor barrier and center strap hole and close the loop by inserting the first collar pin in the last strap hole.

CAUTION

Make sure the vapor barrier on the insulated ducts does not tear during installation to avoid condensation within the ducts.

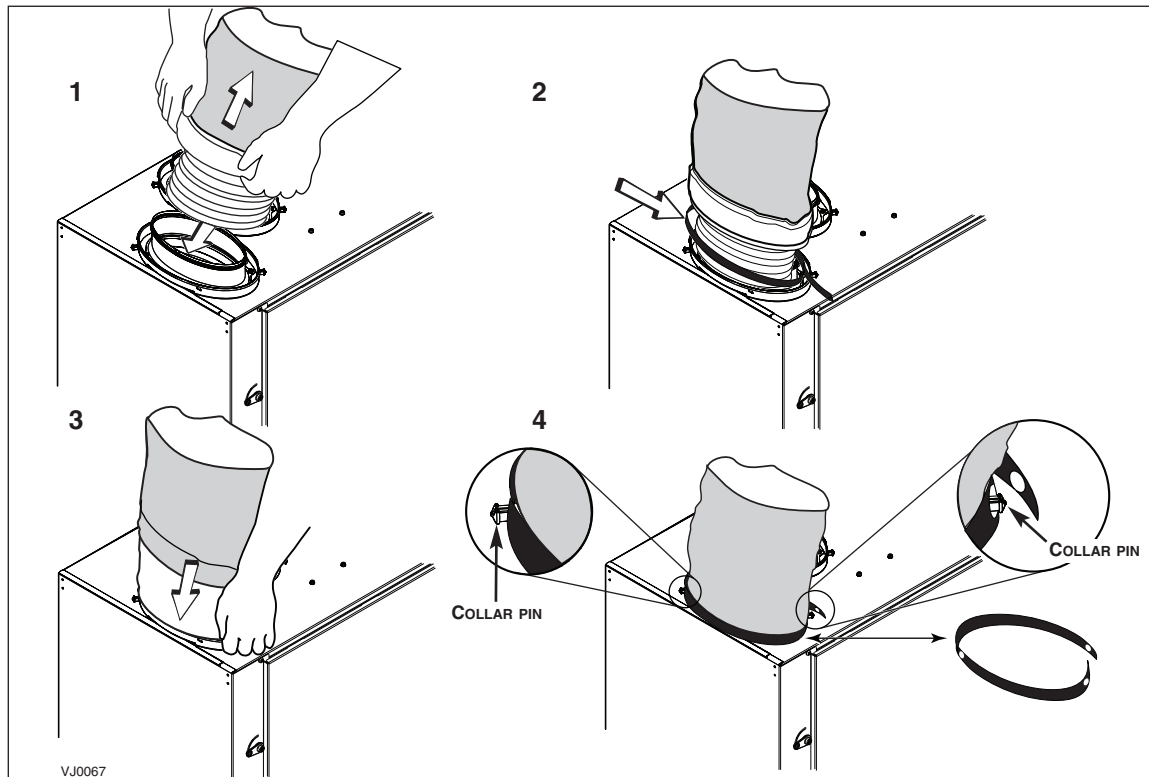

Non-insulated rigid ducts

Use metal screws and duct tape to connect the rigid ducts to the unit ports.

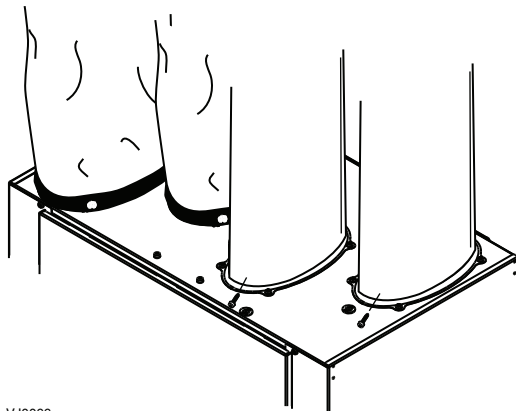

Non-insulated flexible ducts

Use tie wraps to connect the flexible ducts to the unit ports.

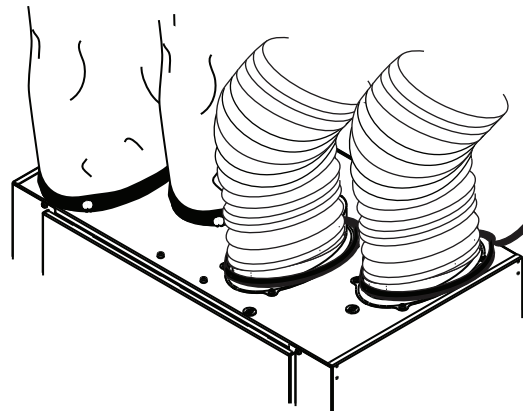

3. INSTALLATION (CONT'D)

3.8 INSTALLING TWO EXTERIOR HOODS

Choose an appropriate location to install the exterior hoods:

- There must be a minimum distance of 6 feet (1.8 m) between the hoods to avoid cross-contamination
- There must be a minimum distance of 18 inches (457 mm) from the ground

Make sure the intake hood is at least 6 feet (1.8 m) away from the following:

- Dryer exhaust, high efficiency furnace vent, central vacuum vent
- Gas meter exhaust, gas barbecue grill
- Any exhaust from a combustion source
- Garbage bin and any other sources of contamination

Refer to figure beside for connecting insulated ducts to the exterior hoods. An "Anti-gust intake hood" should be installed in regions where a lot of snow is expected to fall.

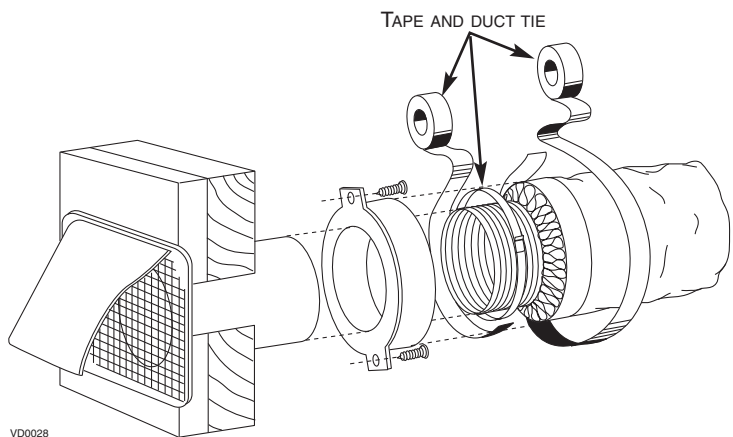
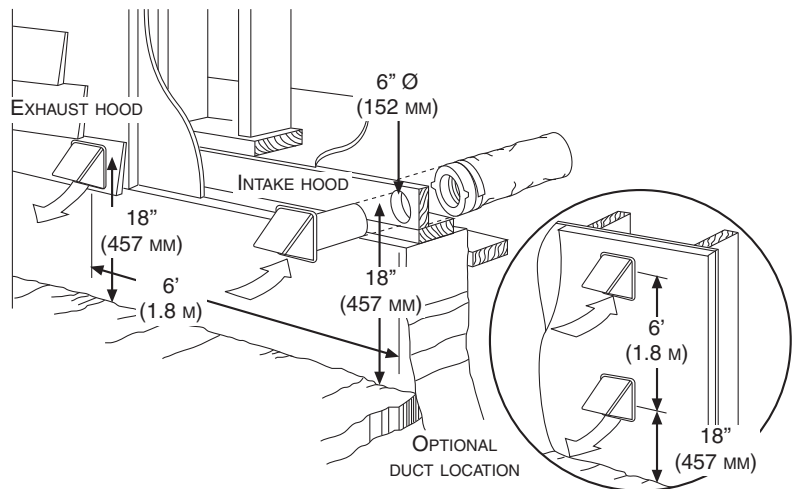

VD0028

3.9 CONNECTING THE DRAIN

Cut 2 sections of the plastic tube, at least 16" (406 mm) long, and attach them to each inner drain fitting, located under the unit.

Join both short sections to the "T" junction and main tube as shown.

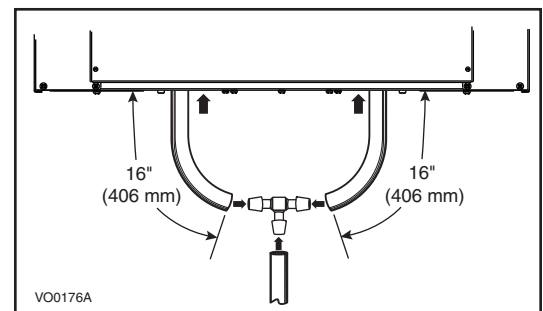

VO0176A

Make a water trap loop in the tube to prevent the unit from drawing unpleasant odors from the drain source. Make sure this loop is located OVER the "T" as shown. Run the tube to the floor drain or to an alternative drain pipe or pail.

IMPORTANT

If using a pail to collect water, locate the tube end approximately 1" from the top of the pail in order to prevent water from being drawn back up into the unit.

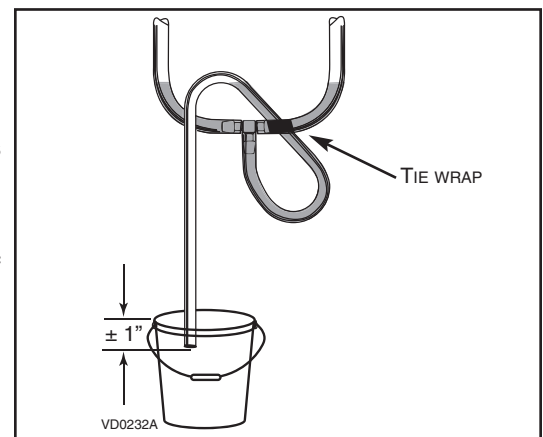

VD0232A

4. CONTROLS

4.1 INTEGRATED CONTROL

All units are equipped with an integrated control located under the unit, on the recessed side of electrical compartment. Plug the unit. Use the push button (1) to control the unit. The LED (2) will then show on which mode the unit is in.

Refer to table below to see how to operate the unit using its integrated control.

PRESS ON PUSH BUTTON	LED COLOR	RESULTS
ONCE	AMBER	UNIT IS ON LOW SPEED
TWICE	GREEN	UNIT IS ON HIGH SPEED
THREE TIMES	NO LIGHT	UNIT IS OFF

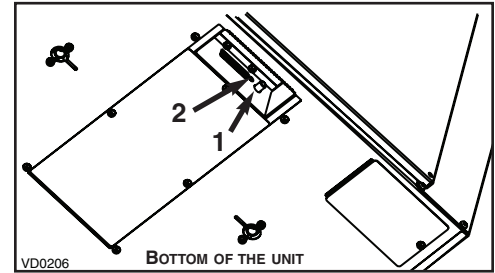

If a problem occurs during the unit operation, its integrated control LED (2) will blink. The color of the blinking light depends on the type of error detected. Refer to Section 9 *Troubleshooting* on page 21 for further details.

4.2 UNITS BOOTING SEQUENCE

The unit booting sequence is similar to a personal computer boot sequence. Each time the unit is plugged after being unplugged, or after a power failure, the unit will perform a 30-second booting sequence before starting to operate.

4.2.1 AVS HRV EKO 1.5 AND HRV 90H-V ECM

During the booting sequence, the integrated control LED will light AMBER for 10 seconds. After that, the LED will light RED for the rest of the booting sequence. During this RED light phase, the unit is checking and resetting the motorized damper position. Once the motorized damper position completely set, the RED light turns off and the booting sequence is done.

NOTE: No command will be taken until the unit is fully booted.

4.2.2 AVS CONSTRUCTO 1.5V AND 90H-V

During the booting sequence, the integrated control LED will light GREEN (unit set in normal defrost) or AMBER (unit set in extended defrost) for 5 seconds, and then will shut off for 2 seconds. After that, the LED will light RED for the rest of the booting sequence. During this RED light phase, the unit is checking and resetting the motorized damper position. Once the motorized damper position completely set, the RED light turns off and the booting sequence is done.

NOTE: No command will be taken until the unit is fully booted.

4. CONTROLS (CONT'D)

4.3 SPEED AND DEFROST SETTINGS FOR AVS HRV EKO 1.5 AND HRV 90H-V ECM UNITS

The special design of AVS HRV EKO 1.5 and HRV 90H-V ECM units offers 4 speed ranges to better meet to different ventilation needs. Refer to the table below to choose the right speed range according to the size of the house:

NOTE: These CFM values are approximate, they may vary according to the installation static pressure.

SPEED RANGE	CFM VALUES	
	MINIMUM SPEED	MAXIMUM SPEED
1 HIGH (FACTORY SET)	80 CFM	157 CFM
2 MED-HIGH	66 CFM	132 CFM
3 MED-LOW	53 CFM	106 CFM
4 LOW	40 CFM	80 CFM

These units are factory set to normal defrost. In cold region (outside temperature -27°C [-17°F] and lower), it may be necessary to setup extended defrost.

DEFROST TABLE	DEFROST CYCLE
1 FACTORY SET	NORMAL
2	EXTENDED

TO CHANGE THE FACTORY SETTINGS, PROCEED AS FOLLOW:

NOTE: Anytime in setting process, if there is no activation on push button for 60 seconds, the unit will automatically exit setting mode, but the settings made before this 60-second delay will remain.

ACTION

- ① During the first 7 seconds of booting sequence, while the integrated control LED is AMBER, press on push button for about 3 seconds.
- ② Set the speed range by pressing consecutively on push button the number of times corresponding to the desired speed range. See table below.

RESULT

- ① The LED will blink RED one time at every 3 seconds to indicate the integrated control is in CFM setup mode (HIGH speed).
- ② At every 3 seconds, the LED will blink RED the number of times corresponding to the chosen speed range. See table below.

NOTE: It is possible to change the selection as many times needed.

SPEED RANGE	PRESS ON PUSH BUTTON	LED BLINKS RED
1 HIGH	ONCE	1 TIME
2 MED-HIGH	TWICE	2 TIMES
3 MED-LOW	THREE TIMES	3 TIMES
4 LOW	FOUR TIMES	4 TIMES

- ③ Press on push button for about 3 seconds to acced setting defrost mode.
- ④ Press on push button twice to set the unit in extended defrost mode.

- ③ The LED will blink GREEN one time at every 3 seconds to indicate the unit is set in normal defrost mode.
- ④ The LED will blink GREEN two times at every 3 seconds to indicate the unit is in extended defrost mode.

NOTE: It is possible to change the selection as many times needed.

DEFROST TABLE	PRESS ON PUSH BUTTON	LED BLINKS GREEN
1 NORMAL	ONCE	1 TIME
2 EXTENDED	TWICE	2 TIMES

- ⑤ Wait 60 seconds OR press 3 seconds on push button to exit setting mode.

- ⑤ The LED will blink and shut off, then light RED (the unit returns in its booting sequence).

4.4 SETTING EXTENDED DEFROST FOR AVS CONSTRUCTO 1.5V AND 90H-V UNITS

These units are factory set to normal defrost. In cold region (outside temperature -27°C [-17°F] and lower), it may be necessary to setup extended defrost. During the first 2 seconds of booting sequence, while the integrated control LED is GREEN, press on push button for 3 seconds to set the unit in extended defrost; the LED will blink AMBER to show the unit is in extended defrost mode. After that, the LED will shut off, then light RED (the unit returns in its booting sequence).

4. CONTROLS (CONT'D)

4.5 ELECTRICAL CONNECTION TO MAIN CONTROLS

For more convenience, these units can also be controlled using an optional main wall control.

NOTES: 1. The integrated control must be turned OFF to use an optional main control.

2. If an optional auxiliary control is used, if activated, this auxiliary control will override the optional main control.

⚠ WARNING

Always disconnect the unit before making any connections. Failure in disconnecting power could result in electrical shock or damage of the wall control or electronic module inside the unit.

CAUTION

Never install more than one optional main wall control per unit. Make sure that the wires do not short-circuit between themselves or by touching any other components on the wall control. Avoid poor wiring connections. To reduce electrical interference (noise) potential, do not run wall control wiring next to control contactors or near light dimming circuits, electrical motors, dwelling/building power or lighting wiring, or power distribution panel.

Use the terminal connector included in the installation kit to perform the electrical connection for main and optional wall controls. Check if all wires are correctly inserted in their corresponding holes in the terminal block. (A wire is correctly inserted when its orange receptacle is lower than another one without wire. On picture beside, wire **A** is correctly inserted, but wire **B** is not.)

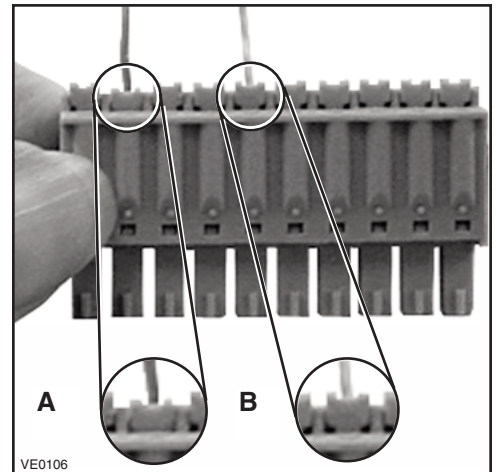

4.5.1 ELECTRICAL CONNECTION TO ALTITUDE (AVS HRV EKO 1.5 UNIT ONLY) OR PLATINUM (HRV 90H-V ECM UNIT ONLY) MAIN WALL CONTROL

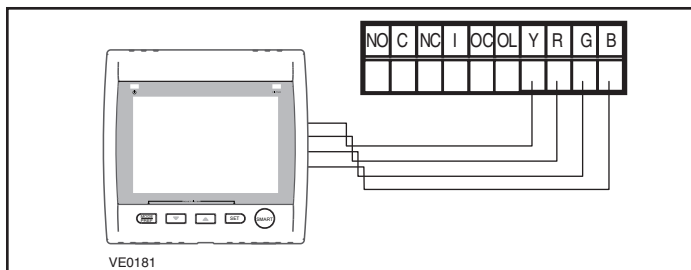

4.5.2 ELECTRICAL CONNECTION TO LITE-TOUCH CONSTRUCTO (AVS CONSTRUCTO 1.5V UNIT ONLY) OR LITE-TOUCH BRONZE (90H-V UNIT ONLY) MAIN WALL CONTROL

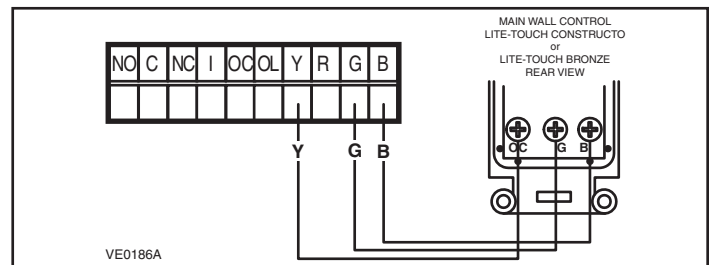

4.5.3 ELECTRICAL CONNECTION TO CONSTRUCTO (AVS CONSTRUCTO 1.5V UNIT ONLY) OR BRONZE (90H-V UNIT ONLY) MAIN WALL CONTROL

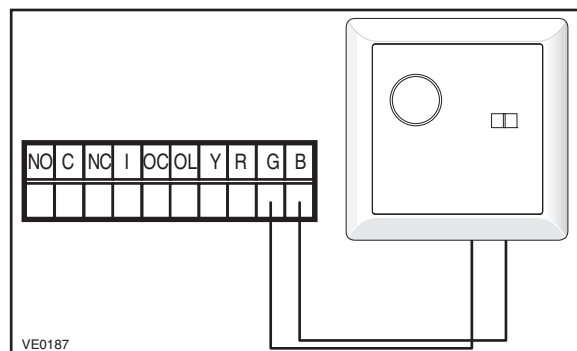

4. CONTROLS (CONT'D)

4.6 ELECTRICAL CONNECTION TO OPTIONAL AUXILIARY CONTROLS

4.6.1 ELECTRICAL CONNECTION TO 20/40/60-MINUTE PUSH BUTTON TIMER OR 60-MINUTE CRANK TIMER (AVS HRV EKO 1.5 AND HRV 90H-V ECM UNITS ONLY)

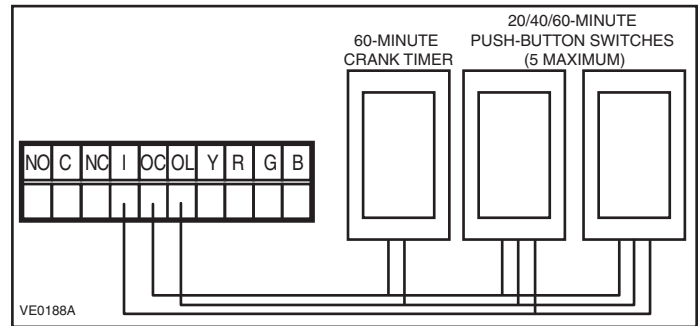

4.6.2 ELECTRICAL CONNECTION TO DEHUMIDISTAT (AVS CONSTRUCTO 1.5V UNIT ONLY), HUMIDITY CONTROL (90H-V UNIT ONLY), 20-MINUTE LIGHTED PUSH BUTTON TIMER OR 60-MINUTE CRANK TIMER (AVS CONSTRUCTO 1.5V AND 90H-V UNITS ONLY)

NOTE: If an optional auxiliary control is activated and then, the Dehumidistat (or Humidity Control) is being activated, the Dehumidistat (or Humidity Control) will override the auxiliary control commands.

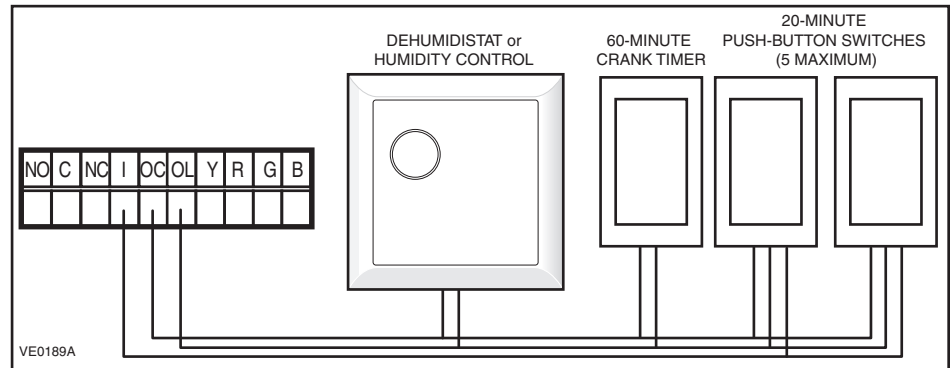

Once the control(s) connections have been made, insert the terminal connector on the recessed side of electrical compartment.

NOTE: For information about the operation of the wall controls, refer to the user guide.

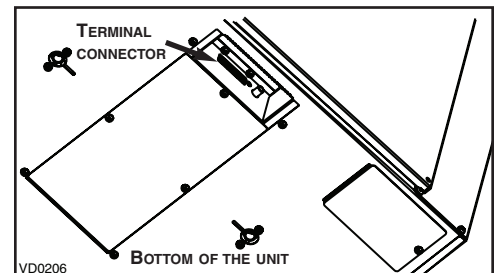

5. ELECTRICAL CONNECTION TO THE FURNACE

⚠ WARNING

Never connect a 120-volt AC circuit to the terminals of the furnace interlock (standard wiring). Only use the low voltage class 2 circuit of the furnace blower control.

For a furnace connected to a cooling system:

On some older thermostats, energizing the “R” and “G” terminals at the furnace has the effect of energizing “Y” at the thermostat and thereby turning on the cooling system. If you identify this type of thermostat, you must use the ALTERNATE FURNACE INTERLOCK WIRING.

STANDARD FURNACE INTERLOCK WIRING

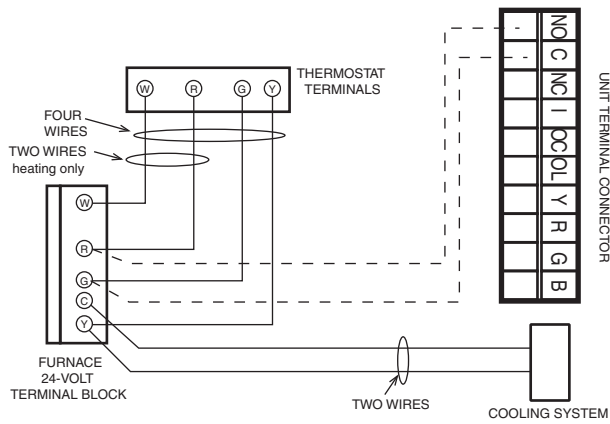

VE0108A

ALTERNATE FURNACE INTERLOCK WIRING

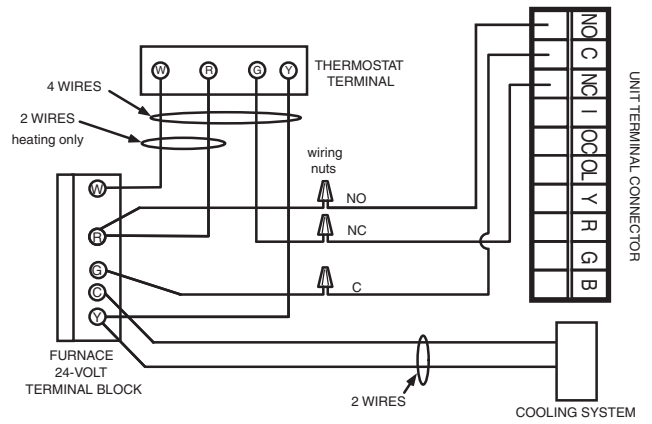

6. WIRING DIAGRAMS

⚠ WARNING

- Risk of electrical shocks. Before performing any maintenance or servicing, always disconnect the unit from its power source.
- This product is equipped with an overload protection (fuse). A blown fuse indicates an overload or a short-circuit situation. If the fuse blows, unplug the product from the outlet. Replace the fuse as per the servicing instructions (follow the marking of product for the proper fuse rating) and verify the product. If the replaced fuse blows, it may be a short-circuit and the product must be discarded or returned to an authorized service center for examination and/or repair.

LOGIC DIAGRAM

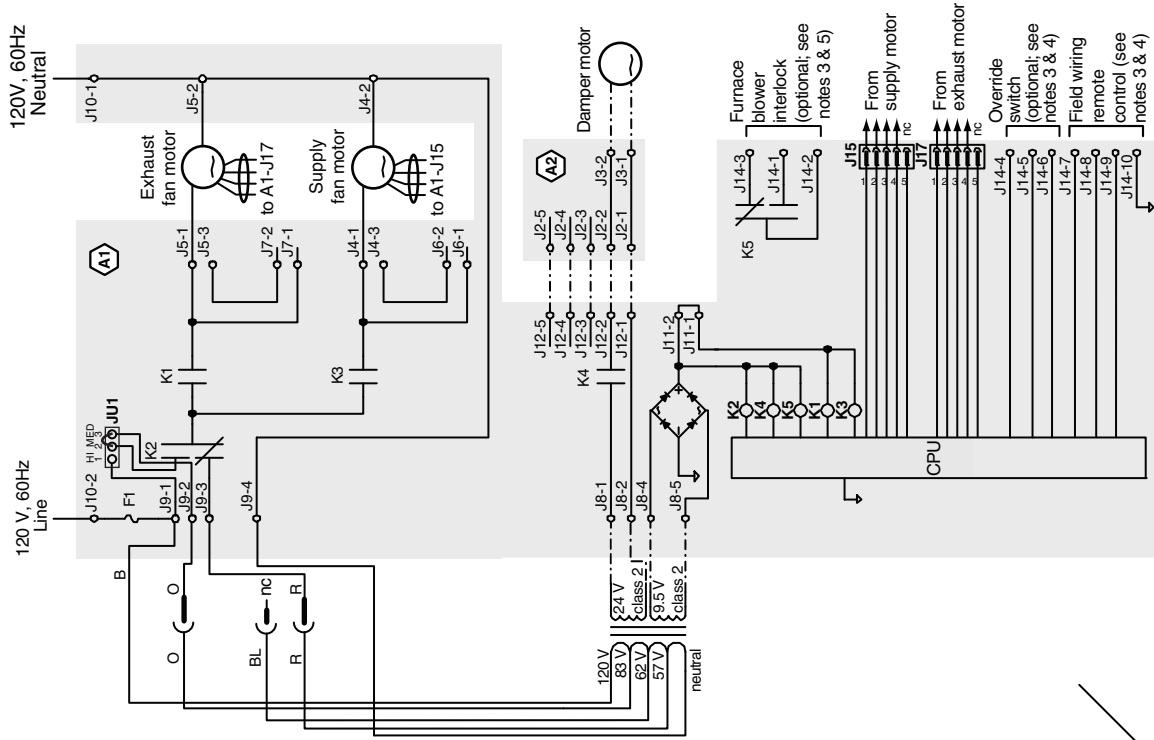

WIRING DIAGRAM

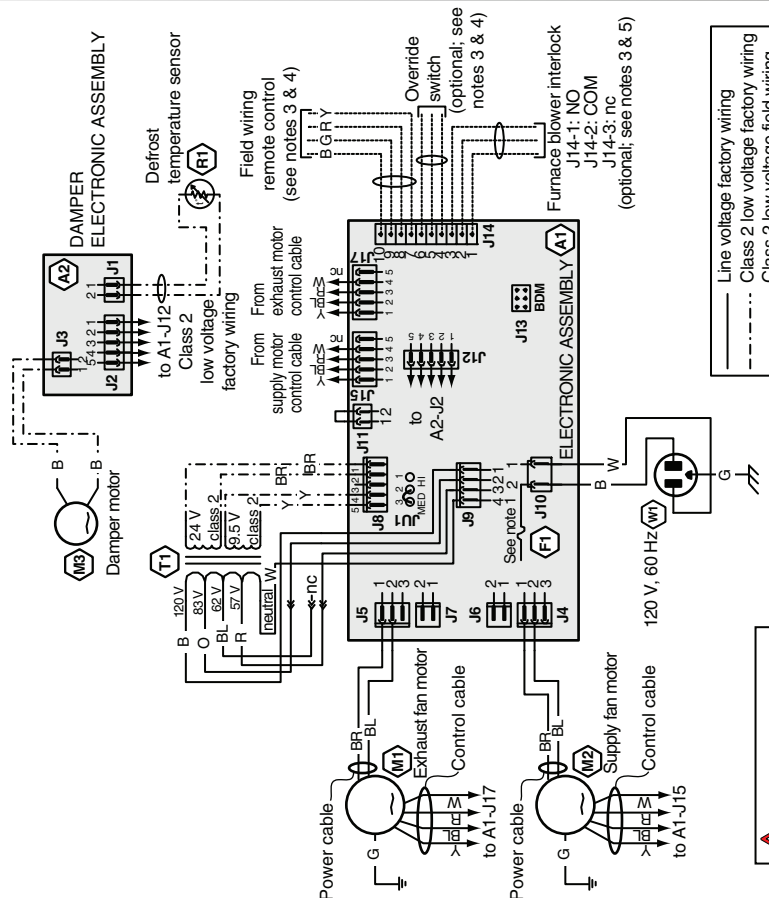

COLOR CODE

B	Line voltage factory wiring
BL	Class 2 low voltage factory wiring
BN	Class 2 low voltage field wiring
BROWN	
GREEN	
ORANGE	
RED	
WHITE	
YELLOW	
nc	no connection

- NOTES**
1. Use specified UL listed/CSA Certified line fuse.
 2. If any of the original wire, as supplied, must be replaced, use the same equivalent wire.
 3. Field wiring must comply with applicable codes, ordinances and regulations.
 4. Remote controls (Class 2 circuit) available, see instruction manual.
 5. Furnace fan circuit must be class 2 circuit only.

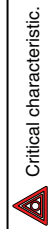

6. WIRING DIAGRAMS (CONT'D)

⚠ WARNING

- Risk of electrical shocks. Before performing any maintenance or servicing, always disconnect the unit from its power source.
- This product is equipped with an overload protection (fuse). A blown fuse indicates an overload or a short-circuit situation. If the fuse blows, unplug the product from the outlet. Replace the fuse as per the servicing instructions (follow the marking of product for the proper fuse rating) and verify the product. If the replaced fuse blows, it may be a short-circuit and the product must be discarded or returned to an authorized service center for examination and/or repair.

AVS CONSTRUCTO 1.5V & 90H-V UNITS

WIRING DIAGRAM



- NOTES**
1. Use specified UL listed/CSA Certified line fuse.
 2. If any of the original wire, as supplied, must be replaced, use the same equivalent wire.
 3. Field wiring must comply with applicable codes, ordinances and regulations.
 4. Remote controls (class 2 circuit) available, see instruction manual.
 5. Furnace fan circuit must be class 2 circuit only.

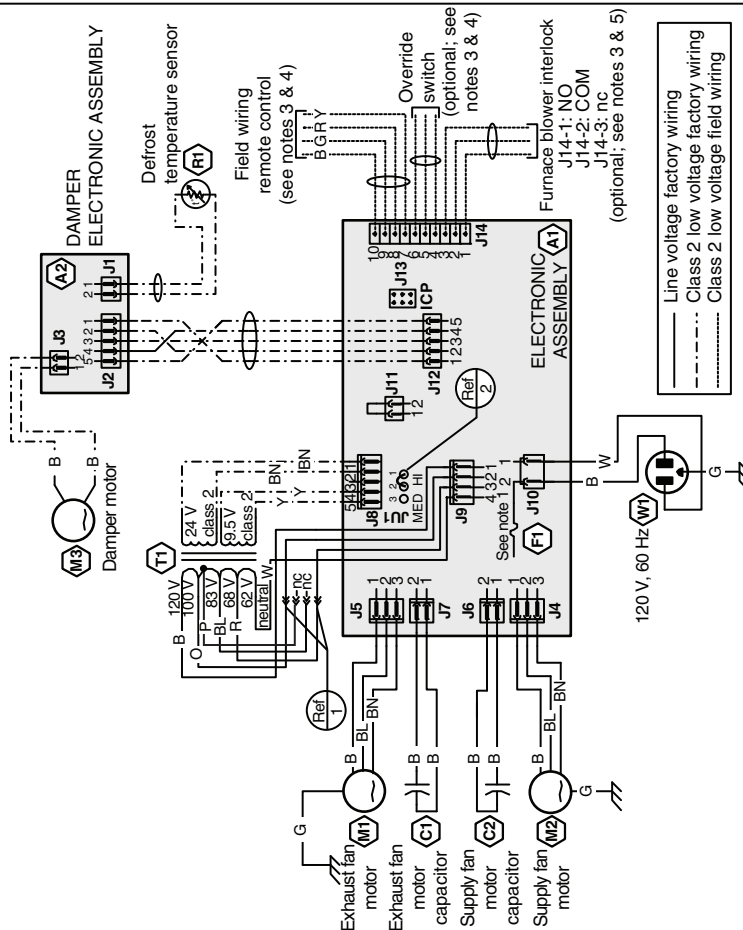

FAN MOTORS SPEED SELECTION

CAUTION: You can change REF 1 or REF 2, but not both at the same time. If you do change REF 1 and REF 2 you will invert fan motor speeds.

REF 1 ORG	REF 1 RED	REF 2	FAN SPEEDS	CFM MAX
Factory shipped ORG to ORG	RED to RED	3 2 1	HI (120V) & LO (62V)	160
ORG to ORG	RED to RED	3 2 1	MED-HI (100V) & LO (62V)	140

COLOR CODE

B	BLACK
BL	BLUE
BN	BROWN
G	GREEN
O	ORANGE
P	PURPLE
R	RED
W	WHITE
Y	YELLOW
nc	no connection

Line voltage factory wiring
 Class 2 low voltage factory wiring
 Class 2 low voltage field wiring

LOGIC DIAGRAM

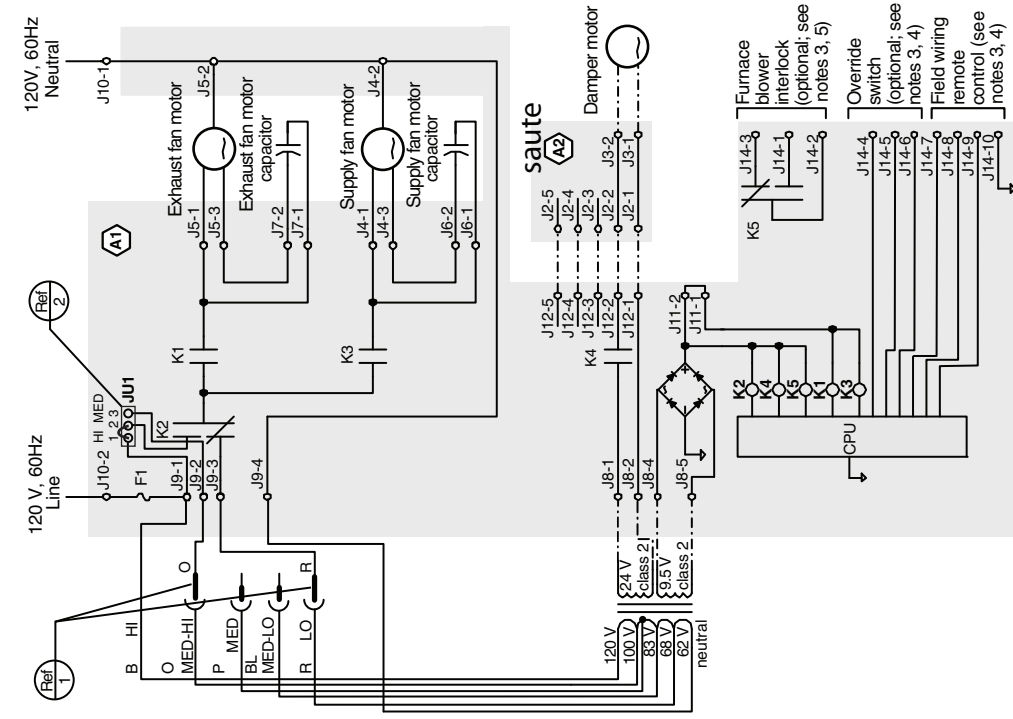

7. BALANCING THE UNIT

7.1 WHAT YOU NEED TO BALANCE THE UNIT

- A magnehelic gauge capable of measuring 0 to 1 inch of water (0 to 249 Pa) and 2 plastic tubes.
- The balancing chart of the unit.

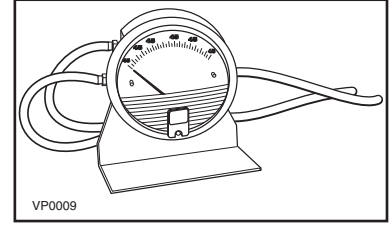

7.2 PRELIMINARY STAGES TO BALANCE THE UNIT

- Seal all the unit ductwork with tape. Close all windows and doors.
- Turn off all exhaust devices such as range hood, dryer and bathroom fans.
- Make sure the balancing dampers are fully open by setting both damper balancing tools completely vertical.
- Make sure all filters are clean (if it is not the first time the unit is balanced).

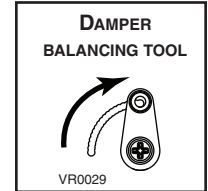

7.3 BALANCING PROCEDURE

1. Set the unit to high speed.

NOTE: Make sure that the furnace/air handler blower is ON if the installation is in any way connected to the ductwork of the cold air return. If not, leave furnace/air handler blower OFF. If the outside temperature is below 0°C/32°F, make sure the unit is not running in defrost while balancing. (By waiting 10 minutes after plugging the unit in, you are assured that the unit is not in a defrost cycle.)

2. Place the magnehelic gauge on a level surface and adjust it to zero.
3. Connect tubing from gauge to EXHAUST air flow pressure taps (the ones with arrows, see insets in illustration beside).
Be sure to connect the tubes to their appropriate *high/low* fittings. If the gauge drops below zero, reverse the tubing connections.
4. Note the CFM value from balancing chart on unit.
5. Repeat steps 3 and 4, but to FRESH air flow pressure taps.
6. Match highest CFM value to lowest by adjusting the balancing damper corresponding to the highest value.

See example below:

Débit/Flow	Frais/Fresh	Vicié/Exhaust
PCM/CFM	Po d'eau/in. w.g.	Po d'eau/in. w.g.
120	0.71	0.73
125	0.67	0.70
130	0.63	0.67
135	0.59	0.64
140	0.55	0.61
145	0.51	0.58
150	0.47	0.55

EXHAUST READING VALUES

FRESH READING VALUES

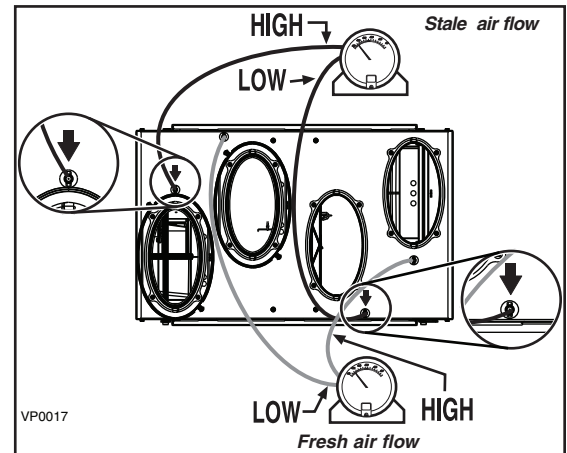

In that case, there is 150 CFM in FRESH air and 125 CFM in EXHAUST air. Then, adjust (close) the FRESH air balancing damper until the FRESH air flow matches the EXHAUST air flow: 125 CFM (**0.67 in. w.g.**) with magnehelic gauge connected to FRESH air flow pressure taps).

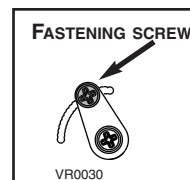

7. Secure both dampers in place with a fastening screw (included).

8. Write the required air flow information on a label and stick it near the unit for future reference (date, maximum speed air flows, your name, phone number and business address).

NOTES: 1. Use conversion chart provided with the unit to convert magnehelic gauge readings to equivalent cfm values.

2. The unit is considered balanced even if there is a difference of ± 10 cfm (or ± 5 l/s or 17 m³/h) between the two air flows.

8. SERVICE PARTS

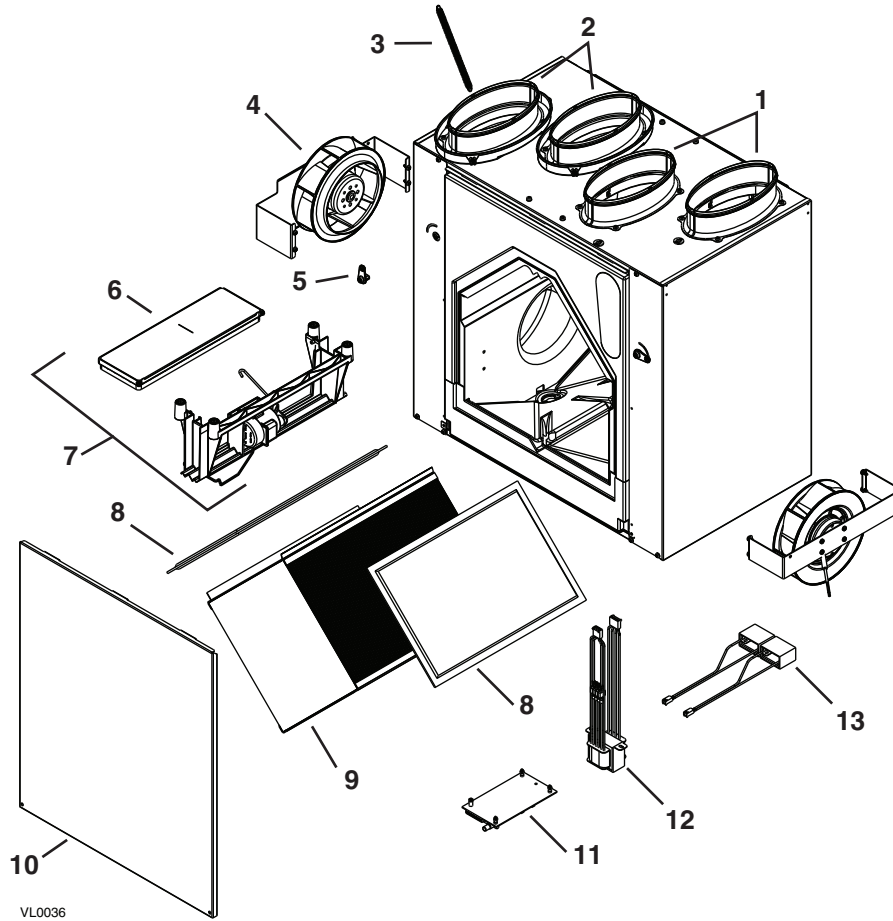

VL0036

ITEM	DESCRIPTION	QTY.	AVS HRV EKO 1.5	AVS CONSTRUCTO 1.5V	HRV 90H-V ECM	90H-V
1	OVAL PORT	2	18206	18206	18206	18206
2	DOUBLE COLLAR OVAL PORT	2	18207	18207	18207	18207
3	EXHAUST DAMPER SPRING	1	18221	18221	18221	18221
4	MOTOR ASSEMBLY	2	18198	18197	18198	18197
5	BALANCING TOOL	2	18220	18220	18220	18220
6	DEFROST DAMPER	1	18200	18200	18200	18200
7	DAMPER SYSTEM ASS'Y (INCLUDING ITEM 6)	1	18199	18199	18199	18199
8	CORE FILTER	2	18205	18204	18205	18204
9	HEAT RECOVERY CORE	1	18202	18203	18202	18203
10	DOOR ASSEMBLY	1	18211	18209	18208	18208
11	PCB	1	18216	18215	18216	18215
12	TRANSFORMER	1	18218	18219	18218	18219
13	CAPACITOR 5 μ F	2	--	16042	--	16042
14	THERMISTOR KIT (NOT SHOWN)	1	15749	15749	15749	15749

9. TROUBLESHOOTING

If the integrated control LED of the unit is flashing, this means the unit sensors detected a problem. See the table below to know where the problem occurs on the unit.

	Error type	Action	Unit status
LED flashes GREEN	Thermistor error	Replace thermistor	Unit works but will defrost frequently
LED flashes AMBER	Damper error	Go to point 6	Unit does not work
LED flashes RED	Motor error	Go to point 9	Unit does not work

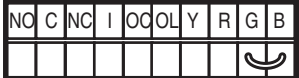
	Problems	Possible causes	You should try this
1	The error code E1 is displayed on Altitude or Platinum wall control screen.	<ul style="list-style-type: none"> The wires may be in reverse position. The wires may be broken. The wires may have a bad connection. 	<ul style="list-style-type: none"> Ensure that the color coded wires have been connected to their appropriate places. Inspect every wire and replace any that are damaged. Ensure the wires are correctly connected.
2	There is no outside temperature displayed on Altitude or Platinum wall control screen  .	<ul style="list-style-type: none"> The unit thermistor may be defective. 	<ul style="list-style-type: none"> Replace the unit thermistor. <p>NOTE: At its very start-up or after a power failure, it takes some minutes before the outside temperature appears on screen. The delay duration depends on which operation mode the wall control is set. The shortest delay is obtained when the wall control is set on MIN or MAX in VENT Mode.</p>
3	Altitude or Platinum wall control screen alternates between normal display and E3.	<ul style="list-style-type: none"> The Altitude or Platinum wall control may be defective. 	<ul style="list-style-type: none"> Disconnect unit for 1 minute and reconnect it. If problem still occurs, replace the Altitude or Platinum wall control.
4	Altitude or Platinum wall control screen alternates between normal display and E4.	<ul style="list-style-type: none"> The Altitude or Platinum wall control may be defective. 	<ul style="list-style-type: none"> Disconnect unit for 1 minute and reconnect it. If problem still occurs, replace the Altitude or Platinum wall control.
5	Unit does not work.	<ul style="list-style-type: none"> The circuit board may be defective. The fuse may be defective. 	<ul style="list-style-type: none"> Unplug the unit. Disconnect the main control and the optional(s) control(s) (if need be). Jump G and B terminals.  <small>VE0097</small> Plug the unit back and wait about 10 seconds. If the motors run on high speed and the damper opens, the circuit board is not defective. Check if fuse F1 is blown. In that case, replace fuse F1 as per product nameplate.
6	The damper actuator does not work.	<ul style="list-style-type: none"> The damper actuator or the integrated damper mechanism may be defective. The circuit board or the transformer may be defective. 	<ul style="list-style-type: none"> Unplug the unit. Disconnect the main control and the optional controls(s) (if need be). Wait 10 seconds and plug the unit back. Check if the damper opens. If not, use a multimeter and check for 24 V AC on J12-1 and J12-2 (in electrical compartment). If there is 24 V AC, replace the entire damper assembly. <p>NOTE: It is normal to experience a small delay (7-8 seconds) before detecting the 24 V AC signal at starting-up. This signal will stay during 17-18 seconds before disappearing.</p> <ul style="list-style-type: none"> If there is no 24 V AC, check for 24V AC between J8-1 and J8-2. If there is 24V AC, replace the circuit board, and if there is no 24V AC, change the transformer.
7	The wall control does not work.	<ul style="list-style-type: none"> The wires may be in reverse position. The wires may be broken. The wire in the wall OR the wall control may be defective. 	<ul style="list-style-type: none"> Ensure that the color coded wires have been connected to their appropriate places. Inspect every wire and replace any that are damaged. Remove the wall control and test it right beside the unit using another shorter wire. If the wall control works there, change the wire. If it does not, change the wall control.

9. TROUBLESHOOTING (CONT'D)

	Problems	Possible causes	You should try this
8	The Dehumidistat (or Humidity control) does not work OR the 20-minute push button timer does not work OR its indicator light does not stay on.	<ul style="list-style-type: none"> The wires may be in reverse position. The Dehumidistat (or Humidity control) or push button may be defective. 	<ul style="list-style-type: none"> Ensure that the color coded wires have been connected to their appropriate places. Jump the OL and OC terminals. If the unit switch to high speed, remove the Dehumidistat or push button and test it right beside the unit using another shorter wire. If it works here, change the wire. If it doesn't, change the Dehumidistat or the push button.  <p style="text-align: right; font-size: small;">VE0098</p>
9	The supply and/or exhaust motor do not work.	<ul style="list-style-type: none"> The fuse may be defective. The jumper JU1 may be in wrong position or missing. Jumper J11 may be missing. <p>For AVS HRV EKO 1.5 and HRV 90H-V ECM units only</p> <ul style="list-style-type: none"> The circuit board or transformer may be defective. <ul style="list-style-type: none"> The motor(s) may be defective. <p>For AVS Constructo 1.5V and 90H-V units only</p> <ul style="list-style-type: none"> The circuit board or transformer may be defective. The motor(s) or capacitor(s) may be defective. 	<ul style="list-style-type: none"> Check if fuse F1 is blown. In that case, replace fuse F1 as per product nameplate. Make sure that jumper is properly located as per wiring diagram in Section 6 <i>WIRING DIAGRAM</i>. Make sure there is a jumper on connector J11. <p>NOTE: Refer to the Section 6 <i>Wiring diagram</i>.</p> <ul style="list-style-type: none"> Press on the integrated control push button until the unit turn on high speed (the LED will light GREEN). Using a multimeter, check the voltage on J4-1 and J4-2 (for supply motor), and on J5-1 and J5-2 (for exhaust motor). If both readings are 120V AC, the circuit board is not defective. If one or both readings are not 120V AC, change the transformer. If no voltage is present, change the circuit board. If the voltage reading is 120V AC on J4 or J5, change the defective motor. <p>NOTE: Refer to the FAN MOTOR SPEED SELECTION table in Section 6 <i>WIRING DIAGRAM</i> to know what the voltage reading must be.</p> <ul style="list-style-type: none"> Press on the integrated control push button until the unit turn on low speed (the LED will light AMBER). Using a multimeter, check the voltage on J4-1 and J4-2 (for supply motor), and on J5-1 and J5-2 (for exhaust motor). Then set the unit on high speed by pressing on the integrated control push button one more time (the LED will light GREEN). Using a multimeter, check the voltage on J4-1 and J4-2 (for supply motor), and on J5-1 and J5-2 (for exhaust motor). If all the readings correspond to the right voltage values, the circuit board is not defective. If one or both readings are different, change the transformer. If no voltage is present, change the circuit board. Using a multimeter, check the ohms value on each motor connectors. For BLUE and BLACK motor wires, the right value is ± 49 ohms. For BLUE and BROWN motor wires, the right value is ± 79 ohms. For BROWN and BLACK motor wires, the right value is ± 126 ohms. If the ohms values are the same, the motor is not defective. Replace the motor capacitor.
10	The defrost cycle does not work (the fresh air duct is frozen) OR the fresh air distributed is very cold.	<ul style="list-style-type: none"> Ice deposits may be hindering the damper operation. The damper rod or the port damper itself may be broken. The damper actuator or circuit board may be defective. 	<ul style="list-style-type: none"> Remove the ice. Inspect these parts and replace if necessary. See point 6.
11	The integrated control push button does not work.	<ul style="list-style-type: none"> The 30-second boot sequence is not completed. 	<ul style="list-style-type: none"> See Section 4.2 <i>Units Booting Sequence</i>.